

三菱工業用ミシン部品カタログ

MITSUBISHI Industrial Sewing Machine Parts Catalog

Model PLK1210

目次	INDEX	Page
① 全 体 構 成	Construction	1
② 本 体 関 係	Arm bed & its accessories	2
③ 上軸、縦軸、天ビン、針棒機構	Arm shaft verticalshaft & thread take-up lever needle bar mechanism	6
④ 中 押 エ 機 構	Presser bar lifting mechanism.....	8
⑤ 下 軸 、 カ マ 機 構	Hook shaft & hook mechnism.....	12
⑥ 糸 切 り 機 構	Thread trimming mechanim.....	14
⑦ ピッカー及び糸切り作動機構	Picker & thread trimmer actuating mechanism.....	16
⑧ X - Y 機 構	X-Y Table mechanism.....	18
⑨ 外 押 エ 機 構	Work holder mechanism.....	20
⑩ 外 押 エ 駆 動 機 構	Work holder driving mechanism.....	22
⑪ ワイパー・スイッチ機構	Wiper & switch mechanism.....	24
⑫ 給 油 機 構	Oil lubrication mechanism.....	26
⑬ 制 御 盤	Control box	28
⑭ 筐 体	Table mechanism.....	30
⑮ 配 線 関 係	Wiring connection mechanism.....	32
⑯ 付 属 品	Accessories	34
⑰ オ プ シ ョ ン パ ー ツ	Option parts	36

2 本体関係 ARM BED & ITS ACCESSORIES

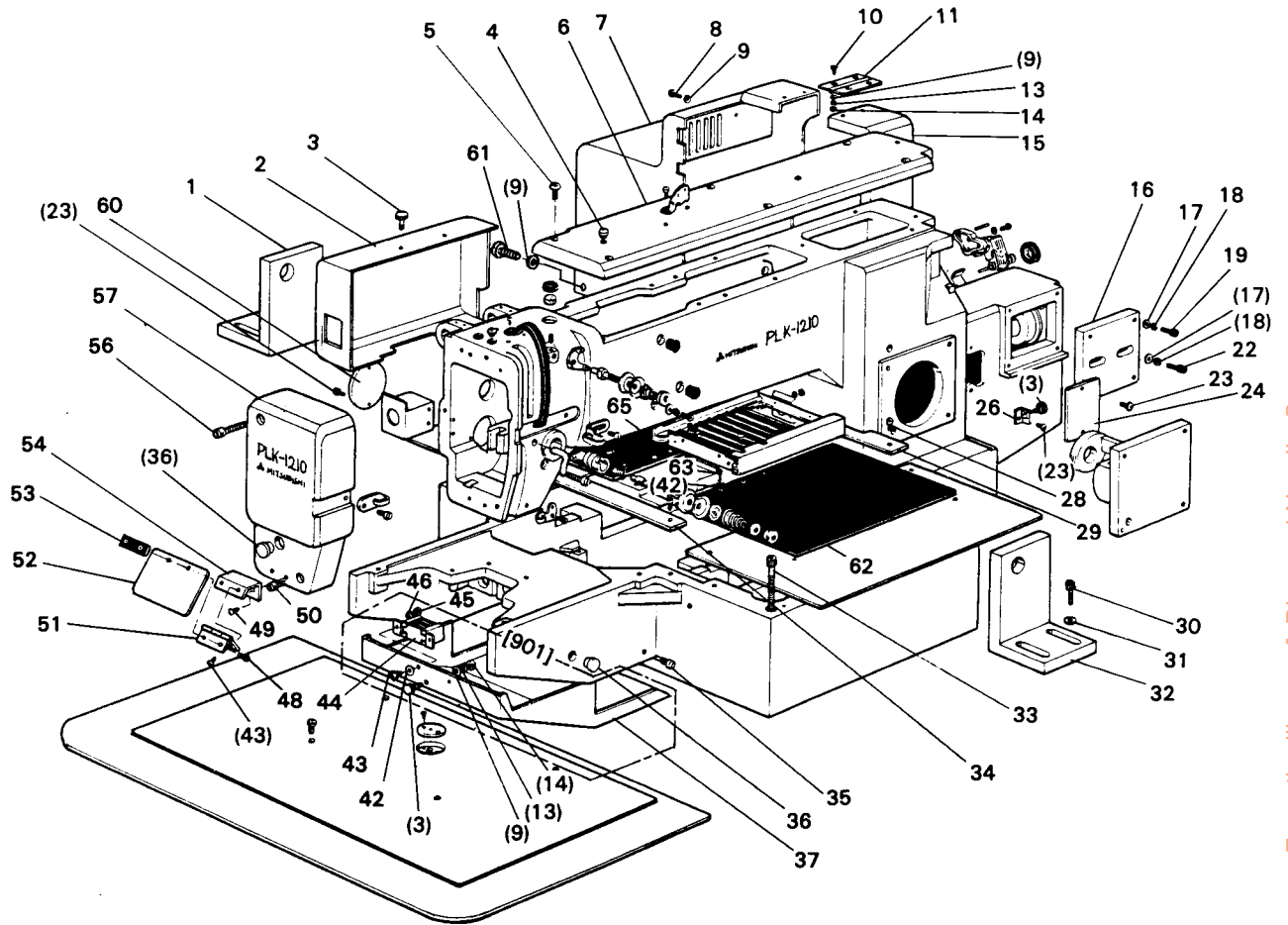

From the library of: Diamond Needle Corp

2 本体関係 ARM BED & ITS ACCESSORIES

Fig. No.	部品コード Parts. No.	部品名	Parts. name	使用 個数 Amt. Req.	資材コード Ref. No.
1	MS 02A2 603	取付台 (左)	Bracket (left)	1	A130C152H02
2	MS 02E0 486	スイッチカバー	Switch cover	1	A130C138G03
3	M9 1005 035	綱首ツマミネジ M4×0.7×8	Screw M4×0.7×8	5	S901Z610H11
4	M9 0570 080	ゴム栓	Rubber plug	3	W502078H01
5	M9 1101 004	プライマネジ ¼(40)×8	Screw ¼ (40)×8	6	W466810H01
6	MS 02A0 600	トップカバー	Top cover	1	A120B027H01
7	MS 02E0 339	モータカバー	Motor cover	1	A120B031G01
8	M9 0414 037	Pナベネジ M4×0.7×4.5	Screw M4×0.7×4.5	2	S900N014P45
9	M9 0451 050	小座金 4	Washer 4	8	S913N010P04
10	M9 4005 037	Pサラネジ M4×0.7×8	Screw M4×0.7×8	4	S900N114P08
11	MS 02A0 739	ヒンジ	Hinge	1	A140D328G01
12					
13	M9 0401 053	バネ座金 4	Washer 4	5	S913N210P04
14	M9 1003 045	ナット M4×0.7	Nut M4×0.7	5	S910N010P04
15	MS 02E0 776	ベルトカバー	Belt cover	1	A130C151G02
16	MS 02A0 603	ブラケット取付台	Adapter	1	A130C124H02
17	M9 0552 050	小座金 5	Washer 5	6	S913N010P05
18	M9 0501 053	バネ座金 5	Spring washer 5	6	S913N210P05
19	M9 5003 021	六角穴付ボルト M5×0.8×12	Bolt M5×0.8×12	4	S903N210P12
20					
21					
22	M9 5011 021	六角穴付ボルト M5×0.8×25	Bolt M5×0.8×25	2	S903N210P25
23	M9 0420 037	SW, PW, Pナベネジ M4×0.7×8	Screw M4×0.7×8	5	S902N034P08
24	MS 02A4 339	カバー	Cover	1	A140D251H01
25					
26	MS 02B0 601	取付金具	Adaper	1	A140D315G01
27					
28	M9 1116 002	平ネジ ¼(40)×8	Screw ¼ (40)×8	17	W501400H01
29	MS 02D2 339	X-Yカバー (右)	X-Y cover (right)	1	A140D220H01
30	M9 6009 021	六角穴付ボルト M6×16	Screw M6×16	4	S903N211P16
31	M9 0104 053	バネ座金 6	Spring washer 6	4	S913N210P06
32	MS 02A3 603	取付台 (右)	Braket (right)	1	A140C152H01
33	M9 5012 021	六角穴付ボルト M5×0.8×130	Bolt M5×0.8×130	4	S903N210P74
34	MS 02D1 339	X-Yカバー (前)	X-Y cover (front)	1	A140D218H01
35	M9 4001 030	特殊ネジ M5×0.8	Screw M5×0.8	1	A140D312H01
36	M9 1180 080	ゴム栓	Rubber plug	5	W502069H01
901	MS 02E1 339	下カバー (組)	Cover (lower) complete	1	A130C447G01
37	MS 02A0 339	下カバー	Cover (lower)	1	A120B030H02
38					
39					
40					
41					
42	M9 0314 050	小座金 3	Washer 3	8	S913N010P02
43	M9 0336 037	Pナベネジ M3×0.5×6	Screw M3×0.5×6	2	S900N012P06
44	MS 02A0 809	マグネットキャッチ	Magnet catch	1	A190D019P01
45	M9 0874 045	ナット M3×0.5	Nut M3×0.5	4	S910N010P02
46	M9 0305 053	バネ座金 3	Washer 3	4	S913N210P02
47					
48	M9 0806 002	平ネジ ⅜(44)×6	Screw ⅜ (44)×6	2	B508857H01
49	M9 1110 002	平ネジ ¼(40)×8	Screw ¼ (40)×8	2	W500294H01
50	M9 1106 003	丸平ネジ ¼(40)×20	Screw ¼ (40)×20	1	W500369H01
51	MS 01A1 739	ヒンジ	Hinge	1	W488942G01
52	MS 01A0 160	アイガード	Eye guard	1	W488562H01
53	MS 01A0 477	当て金	Adapter	1	W488564H01
54	MS 02A0 601	アイガード取付板	Eye guard adapter	1	A140D236H01
55					
56	M9 1075 003	丸平ネジ M4×0.7×30	Screw M4×0.7×30	1	S901N854P30
57	MS 02A0 830	面板	Face plate	1	A130C127H04
58					
59	M9 0420 037	SW, PW, Pナベネジ M4×0.7×8	Screw M4×0.7×8	2	S902N034P08
60	MS 02A5 230	カバー	Cover	1	A140D230H01
61	M9 0410 037	Pナベネジ M4×0.7×8	Screw M4×0.7×8	1	S900N014P08
62	MS 02B1 339	Xカバー板 (右)	X-Cover (right)	1	A140D313H01
63	M9 3003 021	六角穴付ボルト M3×0.5×6	Screw M3×0.5×6	2	S903N219P03
64					
65	MS 02B0 339	Xカバー板 (左)	X-Cover (left)	1	A140D314H01

② 本体関係
ARM BED & ITS ACCESSORIES

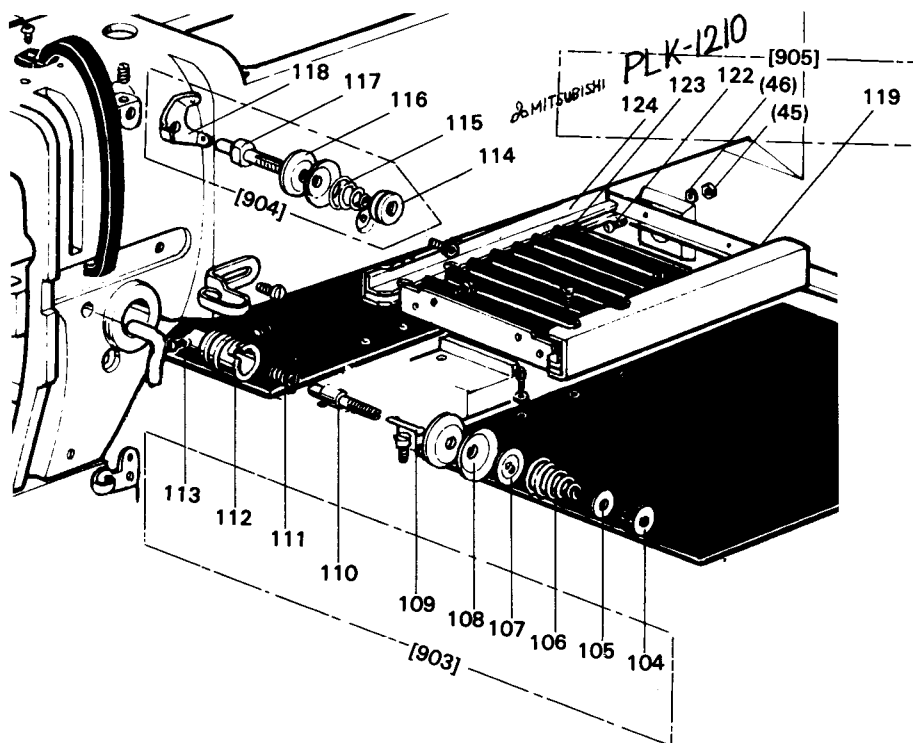
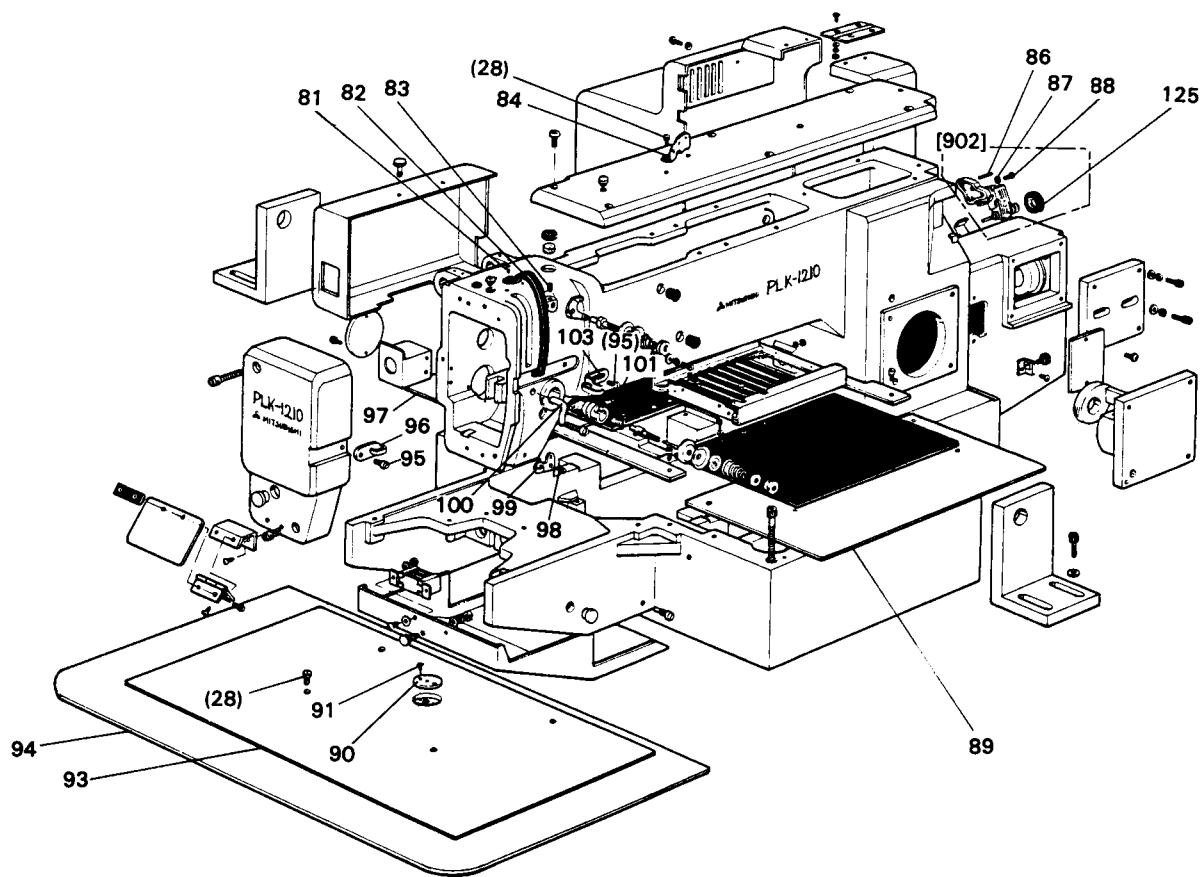

From the library of: Diamond Needle Corp

2 本体関係 ARM BED & ITS ACCESSORIS

Fig. No.	部品コード Parts No.	部品名	Parts name	使用 個数 Amt. Req.	資材コード Ref. No.
81	M9 1107 002	平ネジ $\frac{1}{4}$ (40)×5.5	Screw $\frac{1}{4}$ (40)×5.5	1	W500092H01
82	MF 17B0 584	天ピンカバー	Thread take-up cover	1	W458150H01
83	M9 1108 001	頭ナシ止メネジ $\frac{1}{4}$ (40)×5.5	Screw $\frac{1}{4}$ (40)×5.5	1	B503846H01
84	MF 36A1 180	糸案内(上)	Thread guide	1	W471432H01
85					
86	M9 9082 063	ミソ付ピン	Pin	1	A190D018P01
87	M9 0450 050	ミガキ座金 4	Washer 4	1	S913N040P04
88	M9 1117 002	丸平ネジ $\frac{1}{4}$ (40)×11.4	Screw $\frac{1}{4}$ (40)×11.4	1	B503844H01
902	MS 02E0 190	糸巻仕掛	Bobbin winder complete	1	A130C156G01
89	MS 02D2 339	X-Yカバー(右)	X-Y cover (right)	1	A140D220H01
90	MS 02A1 101	針板 ϕ 2.2	Needle plate ϕ 2.2	1	A140D516H02
91	M9 0612 002	平ネジ $\frac{3}{8}$ (56)×1.8	Screw $\frac{3}{8}$ (56)×1.8	2	W488893H01
92					
93	MS 02A0 797	保護フィルム	Slide plate guard film	1	A140D410H01
94	MS 02A1 470	スベリ板	Slide plate	1	A130C128H01
95	M9 0909 003	丸平ネジ $\frac{3}{8}$ (40)×6	Screw $\frac{3}{8}$ (40)×6	2	W501901H01
96	MG 43A1 181	糸案内(面板)	Thread guide	1	W487127H01
97	MS 02D0 339	X-Yカバー(左)	X-Y cover (left)	1	A140D221H01
98	M9 0906 002	平ネジ $\frac{3}{8}$ (40)×4.5	Screw $\frac{3}{8}$ (40)×4.5	1	W500791H01
99	MQ 50A0 181	糸案内(アームF)	Thread guide	1	W464979H01
100	MF 70A1 180	糸案内	Thread guide	1	W481679H01
101	M9 1506 001	頭ナシ止メネジ $\frac{1}{4}$ (28)×6	Screw $\frac{1}{4}$ (28)×6	1	B509087H01
102					
103	MG 43A0 181	糸案内(中)	Thread guide	1	W487126H01
903	MS 04E0 210	糸調節器(組)	Thread tension regulator complete	1	W346065G05
104	M9 1608 046	調節ナット	Thumb nut	1	W476469H01
105	MT 60A0 802	回り止め	Thumb nut revolution stopper	1	W476470H01
106	MN 10A3 245	円錐バネ	Thread tension spring	1	W461785H01
107	MM 11A0 556	調子皿押エ	Thread tension releasing disc	1	W477611H01
108	MF 10A0 555	調子皿	Thread tension discs	2	W444059H01
109	M9 0204 060	ピン	Thread tension releasing pin	1	B509216H01
110	MF 10A0 553	調子棒	Thread tension stud	1	B419178H01
111	MF 10A0 187	糸取りバネ	Thread take-up spring	1	W486372H01
112	MF 10A0 709	ブッシュ	Thread tension regulator bushing	1	W453140H01
113	M9 0901 002	平ネジ $\frac{3}{8}$ (40)×4	Screw $\frac{3}{8}$ (40)×4	1	W500741H01
904	MF 90E0 550	調節器(組)(プリテンション)	Pre-tension complete	1	W487036G02
114	M9 1101 046	ツマミナット	Thumb nut	1	W501637H01
115	MF 36A0 245	円錐バネ	Thread tension spring	1	W462881H01
116	MF 10A1 555	調子皿	Thread tension discs	2	W501636H01
117	MF 90A0 553	調子棒	Thread tension stud	1	W487037H01
118	MF 90A0 181	糸案内(プリテンション)	Thread guide	1	W487038H01
119	MS 02A1 226	シャバラ受(右)	Shutter holder (right)	1	A130C145G01
120					
121					
122	M9 4006 037	Pサラネジ M3×0.5×6	Screw M3×0.5×6	2	S900N112P06
123	MS 02A0 458	シャバラ	Shutter	1	A130C144H02
124	MS 02A0 226	シャバラ受(左)	Shutter holder (left)	1	A130C146G01
905	MS 02E0 458	シャバラ(組)	Shutter complete	1	A130C438G01
125	MS 03A0 419	ゴム輪	Rubber ring	1	A140D329H01

3 上軸、縦軸、天ビン、針棒機構
**ARM SHAFT VERTICAL SHAFT &
 THREAD TAKE-UP LEVER NEEDLE BAR MECHANISM**

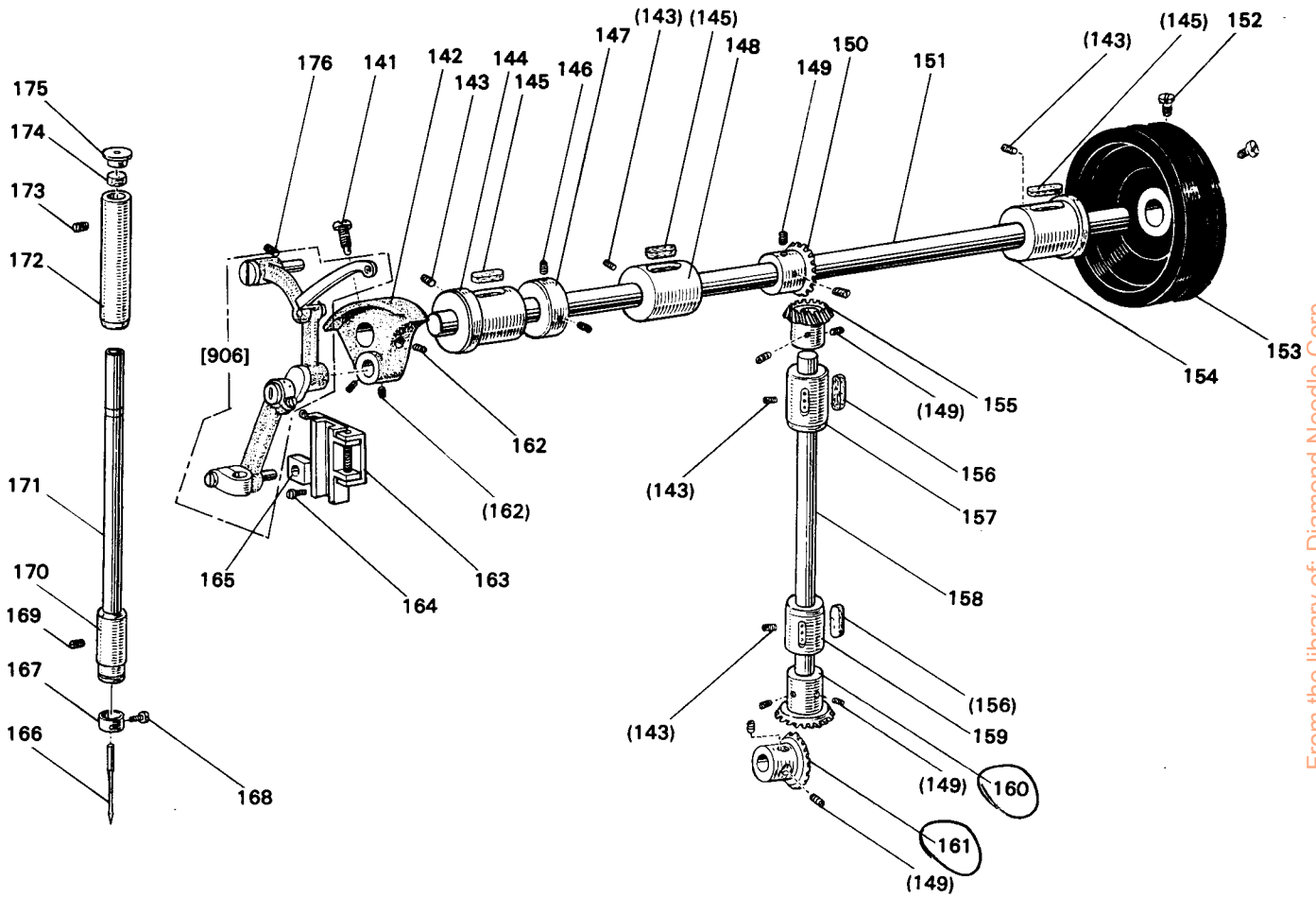

From the library of: Diamond Needle Corp

③ 上軸、豎軸、天ピン、針棒機構

ARM SHAFT VERTICAL SHAFT & THREAD TAKE-UP LEVER NEEDLE BAR MECHANISM

Fig. No.	部品コード Parts No.	部品名	Parts name	使用 個数 Amt. Req.	資材コード Ref. No.
141	M9 1802 006	棒先止メネジ $\frac{1}{8}$ (28)×14	Screw $\frac{1}{8}$ (28)×14	1	B5038s1H01
142	MF 60A1 383	クランク	Crank	1	W450075H03
143	M9 1519 001	頭ナシ止メネジ $\frac{1}{8}$ (28)×6	Screw $\frac{1}{8}$ (28)×6	3	B509087H01
144	MF 60A0 232	上軸メタル(左)	Arm shaft bushing (left)	1	W464011H01
145	MF 60A2 740	フェルト	Felt	3	W501524H01
146	M9 1602 001	頭ナシ止メネジ $\frac{1}{4}$ (40)×4	Screw $\frac{1}{4}$ (40)×4	2	W500036H01
147	MF 70A0 352	カラ	Collar	1	W476422H01
148	MG 41B0 234	上軸メタル(中)	Arm shaft bushing (middle)	1	W481617H01
149	M9 1606 001	頭ナシ止メネジ $\frac{1}{4}$ (40)×7	Screw $\frac{1}{4}$ (40)×7	8	P911000X01
150	MF 40A0 331	傘歯車(上軸)	Bevel gear for arm shaft	1	P611003X02
151	MS 02A0 230	上軸	Arm shaft	1	A130C133H01
152	M9 1502 002	平ネジ $\frac{1}{8}$ (28)×12	Screw $\frac{1}{8}$ (28)×12	2	W500509H01
153	MS 02E0 682	ハズミ車	Pulley	1	A140D231G01
154	MF 60A0 233	上軸メタル(右)	Arm shaft bushing (right)	1	W451575H01
155	MF 40A0 333	傘歯車(豎軸上)	Bevel gear for vertical shaft (upper)	1	P611000X02
156	MF 60A0 740	フェルト	Felt	2	W500042H01
157	MG 37B0 521	豎軸メタル(上)	Vertical shaft bushing (upper)	1	W462791H01
158	MG 41B0 520	豎軸	Vertical shaft	1	W481658H01
159	MF 67B0 522	豎軸メタル(下)	Vertical shaft bushing (lower)	1	W462734H01
160	MF 40A0 334	傘歯車(豎軸下)	Bevel gear for vertical shaft (lower)	1	P611001X02
161	MF 40A0 332	傘歯車(下軸)	Bevel gear for hook shaft	1	P611002X02
162	M9 1606 001	頭ナシ止メネジ $\frac{1}{4}$ (40)×7	Screw $\frac{1}{4}$ (40)×7	3	B504016H01
163	MG 44E0 662	針クガイド(組)	Needle bar connecting link guide	1	W488439G02
164	M9 1110 002	平ネジ $\frac{1}{8}$ (40)×8	Screw $\frac{1}{8}$ (40)×8	2	W500294H01
165	MF 10A0 325	角駒	Square block	1	W443934H01
906	MS 05E0 580	天ピン針ク(組)	Thread take-up lever complete	1	W331012G06
166	MS 02A0 128	針 DP×17#18	Needle DP×17 #18	1	S970005H05
167	MG 42A0 181	糸案内(針棒)	Thread guide	1	W487123H01
168	M9 0815 002	平ネジ $\frac{1}{8}$ (44)×4.5	Screw $\frac{1}{8}$ (44)×4.5	1	W484210H01
169	M9 1102 001	頭ナシ止メネジ $\frac{1}{8}$ (40)×2.7	Screw $\frac{1}{8}$ (40)×2.7	1	W500489H01
170	MQ 50A0 664	針棒メタル(下)	Needle bar bushing (lower)	1	W458121H01
171	MG 44B0 660	針棒	Needle bar	1	W488438H01
172	MF 60A0 663	針棒メタル(上)	Needle bar bushing (upper)	1	W461760H01
173	M9 1503 001	頭ナシ止メネジ $\frac{1}{8}$ (28)×4.5	Screw $\frac{1}{8}$ (28)×4.5	1	B508971H01
174	MF 10A2 740	フェルト	Felt	1	W500003H01
175	MF 60A0 742	蓋	Cap for needle bar bushing (upper)	1	W502181H01
176	M9 1516 001	頭ナシ止メネジ $\frac{1}{8}$ (28)×13	Screw $\frac{1}{8}$ (28)×13	1	W500006H01

From the library of: Durham University

4 中押工機構
PRESSER BAR LIFTING MECHANISM

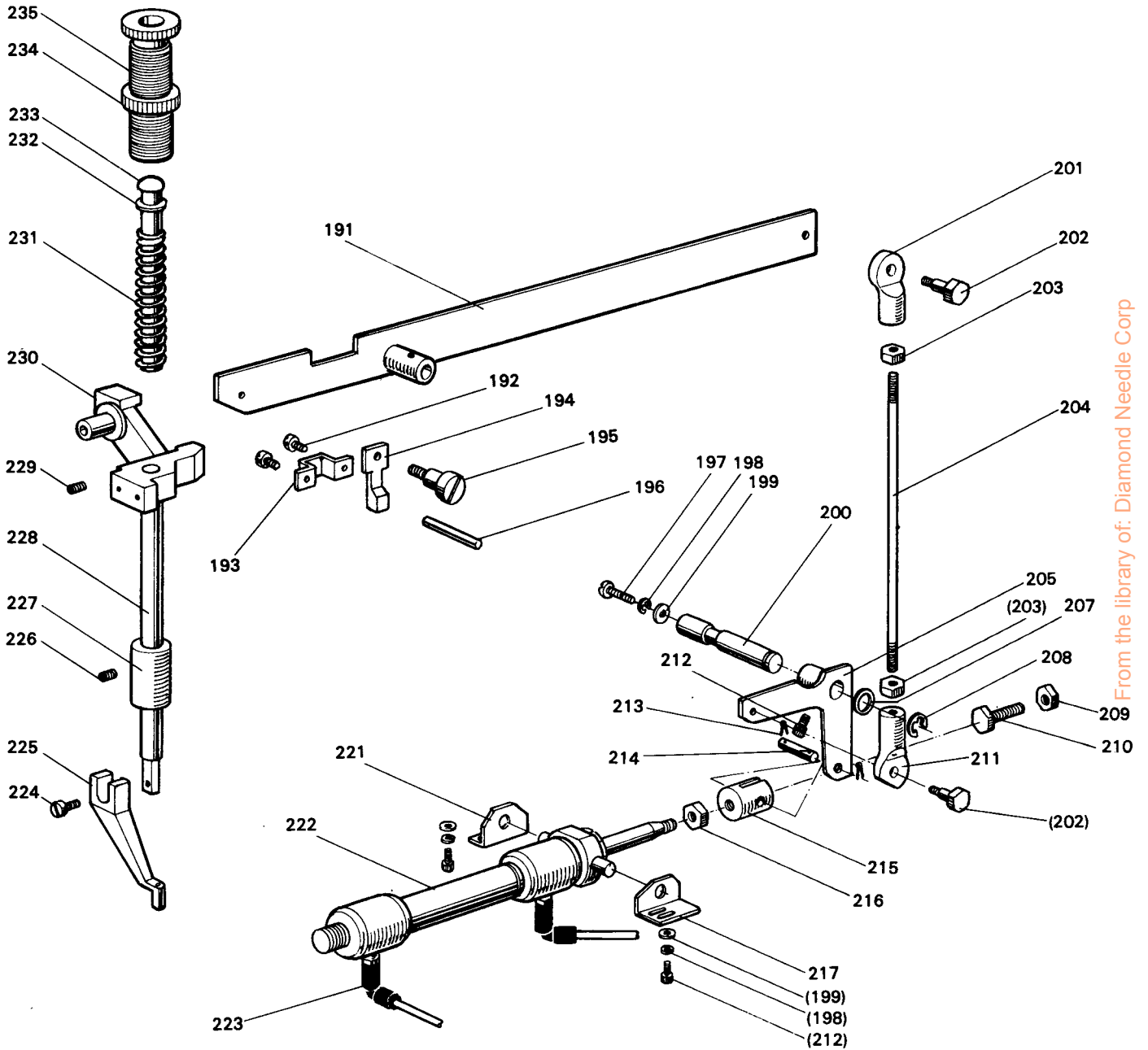

From the library of: Diamond Needle Corp

4 中押工機構 PRESSER BAR LIFTING MECHANISM

Fig. No.	部品コード Parts. No.	部品名	Parts name	使用 個数 Amt. Req.	資材コード Ref. No.
191	MS 02E0 252	押エ上ゲレバ	Lifting lever	1	A130C139G01
192	M9 1109 002	平ネジ $\frac{1}{4}$ (40)×7	Screw $\frac{1}{4}$ (40)×7	2	W500511H01
193	MG 30A0 154	案内金	Guide plate	1	W483466H01
194	MG 30B1 222	糸ユルメ	Thread releasing cam	1	W483465H02
195	M9 1225 015	平ネジ $\frac{3}{8}$ (28)×5.5	Screw $\frac{3}{8}$ (28)×5.5	1	A140D355H01
196	M9 0421 060	糸ユルメピン	Thread releasing pin	1	W502957H07
197	M9 0508 037	Pナベネジ M5×0.8×10	Screw M5×0.8×10	1	S900N015P10
198	M9 0501 053	バネ座金 5	Spring washer 5	5	S913N210P05
199	M9 0550 050	ミガキ座金 5	Washer 5	5	S913N040P05
200	MS 02A6 454	軸	Shaft	1	A140D268H01
201	MF 60A0 591	接手	Connector	1	W462748H01
202	M9 0201 017	ボルト段付	Bolt	2	A140D266H01
203	M9 1251 045	ナット $\frac{3}{8}$ (32)	Nut $\frac{3}{8}$ (32)	2	B509177H01
204	M9 1204 023	植込ミボルト	Connecting bolt	1	A140D255H01
205	MS 02E0 763	ベルクランク	Bell crank	1	A140D267G01
206					
207	M9 0815 050	小座金 8	Washer 8	1	S913N010P08
208	M9 0511 065	E形止メ輪 6	E-type reatining ring 6	1	S922N210P60
209	M9 2008 045	ナット M8	Nut M8	1	S910N010P08
210	M9 8008 022	UPボルト M8×20	Bolt M8×20	1	S903N412P20
211	MS 02A0 784	接手	Connector	1	A140D265G01
212	M9 5009 021	六角穴付ボルト M5×0.8×8	Bolt M5×0.8×8	5	S903N210P08
213	M9 0518 060	スナップピン	Snap pin	2	S921N020P06
214	M9 0613 060	ピン	Pin	1	A140D271H01
215	MS 02A1 571	継手	Connector	1	A140D270H01
216	M9 2008 045	ナット M8(細目)	Nut M8	1	S910N010P08
217	MS 02A3 601	取付足	Adapter	1	A140D257H02
218					
219					
220					
221	MS 02B1 601	取付足	Adapter	1	A140D269H02
222	MS 02A2 434	エアシリンダ	Air cylinder	1	A190N011P01
223	MS 02A5 571	ワンタッチ継手	Connector	2	A190N012P01
224	M9 0922 002	平ネジ $\frac{1}{4}$ (40)×8	Screw $\frac{1}{4}$ (40)×8	1	W464016H01
225	MV 30A0 256	中押エ	Presser foot	1	A130C201H01
226	M9 1102 001	頭ナシ止メネジ $\frac{1}{4}$ (40)×2.7	Screw $\frac{1}{4}$ (40)×2.7	1	W500489H01
227	MG 30B0 267	押エ棒メタル	Presser bar bushing	1	W462887H01
228	MF 10A0 262	押エ棒	Presser bar	1	W502079H01
229	M9 1508 001	頭ナシ止メネジ $\frac{1}{4}$ (28)×8	Screw $\frac{1}{4}$ (28)×8	1	B509088H01
230	MG 41B0 265	押エ棒ダキ	Presser bar holder	1	W481630G01
231	MS 02A0 259	押エバネ	Presser bar spring	1	A140D375H01
232	M9 0620 050	小座金	Washer	1	S913N010P06
233	MF 20A0 703	案内棒	Presser bar guide	1	W475491H01
234	M9 3202 047	特殊ナット $\frac{1}{2}$ (28)	Special nut $\frac{1}{2}$ (28)	1	W471438H01
235	M9 3209 035	ツマミネジ $\frac{1}{2}$ (28)×43	Thumb screw $\frac{1}{2}$ (28)×43	1	W481436H01

4 中押工機構
PRESSER BAR LIFTING MECHANISM

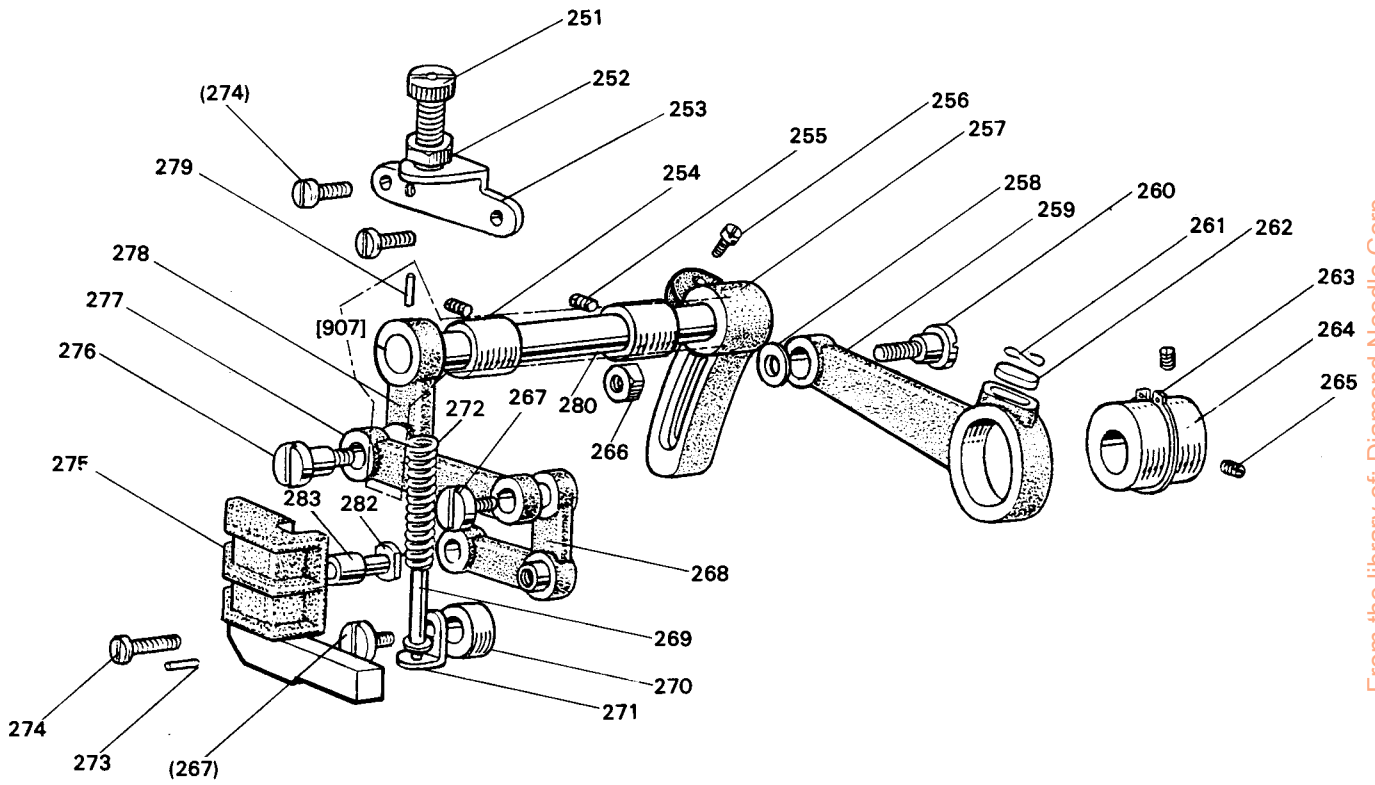

From the library of: Diamond Needle Corp

4 中押工機構 PRESSER BAR LIFTING MECHANISM

Fig. No.	部品コード Parts. No.	部品名	Parts name	使用 個数 Amt. Req.	資材コード Ref. No.
251	M9 1801 035	調節ネジ $\frac{3}{8}$ (28)×35	Feed regulating screw $\frac{3}{8}$ (28)×35	1	W502411H01
252	M9 1802 045	ナット $\frac{3}{8}$ (28)	Nut $\frac{3}{8}$ (28)	1	B508961H01
253	MG 30B1 261	押工調節台	Presser regulating bracket	1	W480473H01
254	MG 30A0 833	送り軸メタル (上部上下)	Feed lifting rock shaft bushing	2	W483459H01
255	M9 1108 001	頭ナシ止メネジ $\frac{1}{4}$ (40)×5.5	Screw $\frac{1}{4}$ (40)×5.5	2	B503846H01
256	M9 1603 003	丸平ネジ $\frac{1}{4}$ (24)×16	Screw $\frac{1}{4}$ (24)×16	1	W501009H01
257	MS 02A0 463	上部上下送り腕 (右)	Feed lifting rock shaft crank (right)	1	A140D217H01
258	M9 0601 050	ミガキ座金 6	Washer 6	1	S913N040P06
259	MG 30B0 384	クランクロッド	Feed connecting crank rod	1	W480485H01
260	M9 1551 015	段付平ネジ M6×0.75×24	Screw M6×0.75×24	1	W480471H02
261	MF 60A0 700	バネ	Spring for felt stopper	1	W500836H01
262	MF 60A1 740	フェルト	Felt	1	W500738H01
263	M9 0325 065	C形止メ輪	C-type stop ring	1	S922N010P25
264	MG 30A0 760	偏心輪	Feed lifting eccentric	1	W483455H01
265	M9 1606 001	頭ナシ止メネジ $\frac{1}{4}$ (40)×7	Screw $\frac{1}{4}$ (40)×7	2	B504016H01
266	M9 1572 045	Uナット 6×0.75	U-nut 6×0.75	1	S542112H01
267	M9 1210 002	平ネジ $\frac{3}{8}$ (28)	Screw $\frac{3}{8}$ (28)	2	W501247H01
268	MG 10B0 763	ベルクランク	Bell crank	1	W461042H01
269	MG 30B0 732	案内金 (組)	Spring guide bar complete	1	W464020G01
270	MS 01A2 352	カラ	Collar	1	A140D423H01
271	MG 30B0 226	押工板支エ	Adapter	1	W461057H01
272	MG 10B0 259	押エバネ	Presser spring	1	W502462H01
273	M9 0301 064	スプリングピン	Spring pin	2	S921N333P08
274	M9 1110 002	平ネジ $\frac{1}{4}$ (40)×8	Screw $\frac{1}{4}$ (40)×8	3	W500294H01
275	MS 02E0 765	ベルクランク支エ (組)	Bell crank guide bracket complete	1	A140D824H01
276	M9 1681 015	段付平ネジ $\frac{1}{4}$ (40)×12	Screw $\frac{1}{4}$ (40)×12	1	W480472H01
277	MG 10B0 910	リンク	Feed lifting rock shaft link	1	W457552H01
907	MS 02E0 460	上部上下腕 (左)(組)	Feed lifting rock shaft complete	1	A141D121G01
278	MS 02A0 462	上部上下腕 (左)	Upper feed lifting rock shaft crank	1	A141D122H01
279	M9 1506 022	テーパピン	Taper pin	1	W488368H01
280	MS 02A0 460	上部上下軸	Feed lifting rock shaft	1	A141D123H01
281					
282	M9 0507 063	コ口軸	Bell crank guide pin	1	W502457H01
283	MG 10B0 411	コ口	Roller	1	W501534H01

From the library of: Diamond Cutters Co. Ltd.

5 下軸、カマ機構
HOOK SHAFT & HOOK MECHANISM

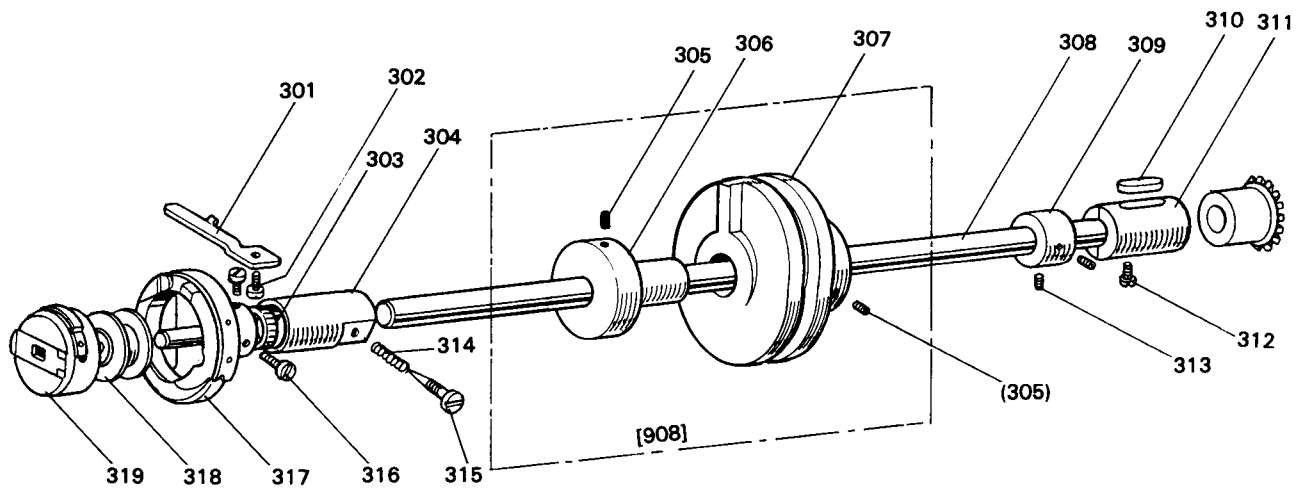

From the library of: Diamond Needle Corp

5 下軸、カマ機構

HOOK SHAFT & HOOK MECHANISM

Fig. No.	部品コード Parts. No.	部 品 名	Parts name	使用 個数 Amt. Req.	資 材 コ ー ド Ref. No.
301	MF 20A0 229	内ガマ止メ	Hook positioner	1	W468837H01
302	M9 1118 002	平ネジ $\frac{1}{4}$ (40)×10	Screw $\frac{1}{4}$ (40)×10	1	B509061H01
303	M9 0801 086	オイルシール G 8×15×3	Oil seal	1	W468802H01
304	MS 02E0 451	下軸メタル (左)(組)	Hook shaft bushing complete (left)	1	W349728G02
908	MF 95E0 350	糸切りカム (組)	Thread trimmer cam complete	1	A130C002G01
305	M9 1601 020	六角穴付止メネジ $\frac{1}{4}$ (40)×6	Screw $\frac{1}{4}$ (40)×6	4	W462662H01
306	MF 90A0 750	ブッシュ	Hook shaft collar	1	A140D003H01
307	MF 95A0 350	糸切りカム	Thread trimmer cam	1	A130C001H01
308	MS 02A0 450	下軸	Hook shaft	1	A130C134H01
309	MF 10A0 352	カラ	Collar for hook shaft	1	B422844H01
310	MF 60A0 740	フェルト	Felt	1	W500042H01
311	MG 37B0 452	下軸メタル (右)	Hook shaft bushing (right)	1	W462738H01
312	M9 1117 002	丸平ネジ $\frac{1}{4}$ (40)×13	Screw $\frac{1}{4}$ (40)×13	1	B503844H01
313	M9 1503 001	頭ナシ止メネジ $\frac{1}{4}$ (28)×4.5	Screw $\frac{1}{4}$ (28)×4.5	2	B508971H01
314	MG 30A0 700	バネ	Spring	1	W487009H01
315	M9 0811 006	棒先平ネジ M3×0.35×9.5	Screw M3×0.35×9.5	1	W487008H01
316	M9 1103 002	平ネジ $\frac{1}{4}$ (40)×5	Screw $\frac{1}{4}$ (40)×5	2	B509062H01
317	MG 44B0 120	カマ	Hook complete	1	P975040X02
318	MG 44B0 123	ボビン	Bobbin	1	W470215H02
319	MS 02E0 125	ボビンケース	Bobbin case complete	1	A190D034P01

6 糸切り機構
THREAD TORIMMING MECHANISM

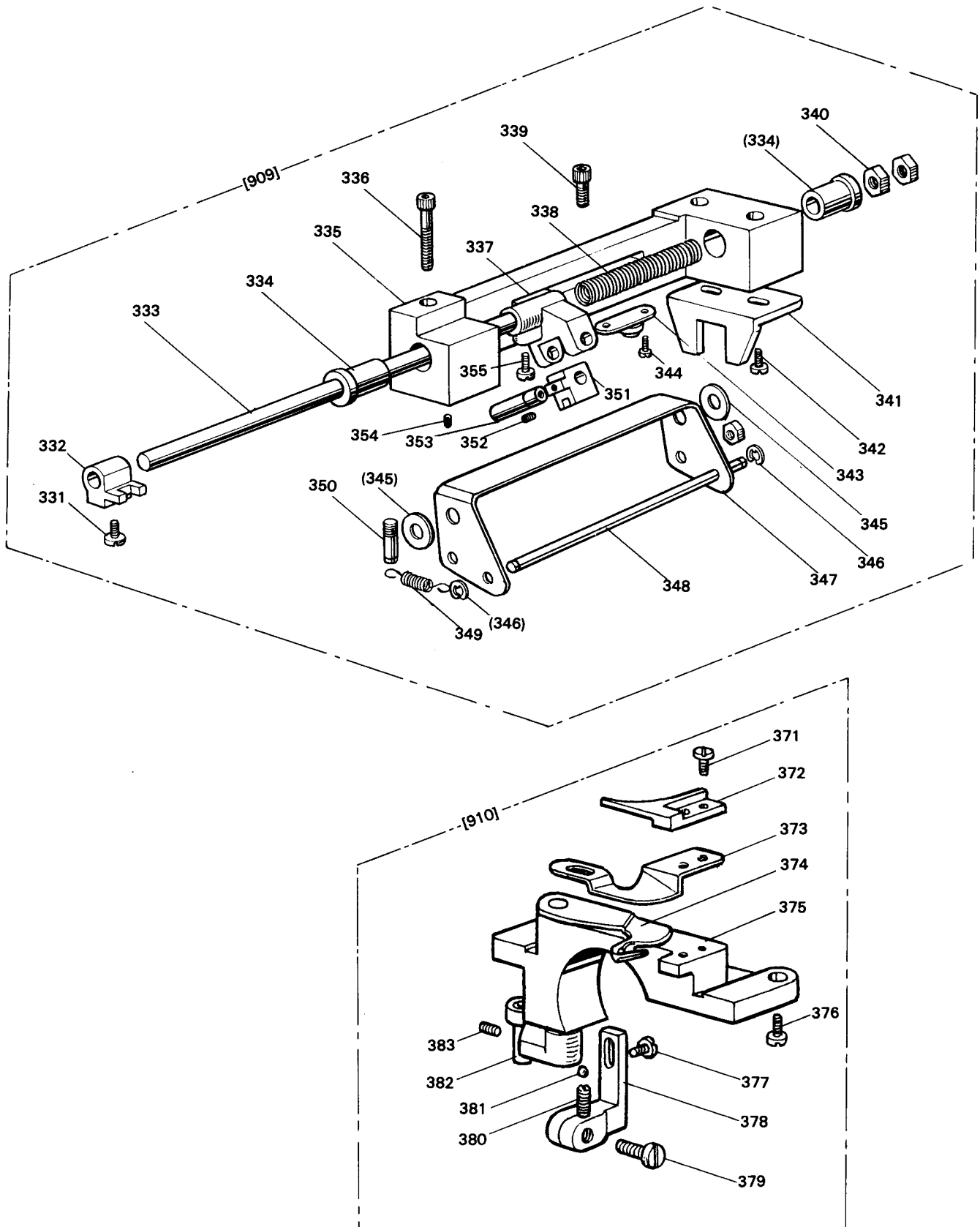

From the library of: Diamond Needle Corp

6 糸切り機構 THREAD TRIMMING MECHANISM

Fig. No.	部品コード Parts. No.	部品名	Parts name	使用 個数 Amt. Req.	資材コード Ref. No.
331	M9 1516 002	平ネジ $\frac{1}{8}(28) \times 8.5$	Screw $\frac{1}{8}(28) \times 8.5$	2	W502945H02
332	MF 90A1 744	メス駆動二又	Knife driving fork	1	W487051H02
333	MF 90A0 348	カム軸	Cam shaft	1	W487046H01
334	MF 90A0 833	カム軸メタル	Bushing for cam shaft	2	W487039H02
335	MS 02A0 348	カム軸取付台	Cam shaft bracket	1	A140D227H01
336	M9 6010 021	六角穴付ボルト M6×35	Bolt M6×35	1	S903N211P35
337	MF 90A0 351	カム追従腕	Cam follower crank	1	W344957H02
338	MF 90A1 572	ツルマキバネ	Spring	1	W487050H02
339	M9 6006 021	六角穴付ボルト M6×12	Screw M6×12	1	S903N211P12
340	M9 2001 045	ナット $\frac{5}{16}(24)$	Nut $\frac{5}{16}(24)$	2	W501512H01
341	MF 95A0 477	ストップ板	Stopper	1	A140D011H01
342	M9 1118 902	平ネジ $\frac{1}{8}(40) \times 10$	Screw $\frac{1}{8}(40) \times 10$	2	B509061H01
343	MF 90E1 410	コロ (組)	Roller complete	1	W487157G01
344	M9 1110 002	平ネジ $\frac{1}{8}(40) \times 8$	Screw $\frac{1}{8}(40) \times 8$	2	W500294H01
345	M9 0814 050	座金	Washer	2	W487040H01
346	M9 0519 065	E形止メ輪 4	E-type retaining ring 4	2	S922N210P40
347	MF 90A1 430	糸切り作動腕 (組)	Actuating crank complete	1	W487092G01
348	M9 0510 060	糸切り作動ピン	Actuating pin	1	W487042H01
349	MF 90A2 572	ツルマキバネ	Spring	1	W487173H01
350	M9 1101 030	バネカケピン	Pin for spring	1	W502032H01
351	MF 90A0 665	コロ軸ダキ	Roller shaft bracket	1	W487049H02
352	M9 1352 020	六角穴付止メネジ M5×5	Screw M5×5	1	W488511H01
353	MF 95E0 410	コロ軸 (組)	Roller shaft complete	1	A130C053G01
354	M9 1109 001	頭ナシ止メネジ $\frac{1}{8}(40) \times 6.6$	Screw $\frac{1}{8}(40) \times 6.6$	2	W500985H01
355	M9 1516 002	平ネジ $\frac{1}{8}(28) \times 8.5$	Screw $\frac{1}{8}(28) \times 8.5$	2	W502945H02
909	MS 02E0 348	カム軸取付台 (組)	Cam shaft bracket complete	1	W344958G06
371	M9 0803 003	丸平ネジ $\frac{1}{8}(44) \times 6$	Screw $\frac{1}{8}(44) \times 6$	2	W502920H01
372	MF 90A0 838	固定メス	Fixed knife	1	W344956H02
373	MF 90A0 180	糸案内	Thread guide for knife	1	W344976H02
374	MF 90B2 838	移動メス (組)	Movable knife complete	1	W344947G02
375	MF 90A2 839	メス台	Knife bracket	1	W344954H02
376	M9 1204 003	丸平ネジ $\frac{3}{16}(28) \times 12$	Screw $\frac{3}{16}(28) \times 12$	2	B508978H01
377	M9 0910 003	丸平ネジ $\frac{3}{16}(40) \times 7$	Screw $\frac{3}{16}(40) \times 7$	2	B509270H01
378	MF 90A0 839	移動メス調節台	Adjusting bracket	1	W487156H01
379	M9 1112 002	平ネジ $\frac{1}{8}(40) \times 18$	Screw $\frac{1}{8}(40) \times 18$	1	W501889H01
380	M9 1110 030	移動メス調節ネジ	Screw	1	W488922H01
381	M9 8001 070	鋼球 ($\frac{3}{16}$)	Steel ball	1	W469183H01
382	MF 90A2 228	移動メス腕	Movable knife crank	1	W487095G02
383	M9 1050 020	六角穴付止メネジ M4×5	Screw M4×5	1	W488510H01
910	MF 90E1 199	メス台 (組)	Knife base complete	1	W231513G03

7 ピッカー及び糸切り作動機構
PICKER & THREAD TRIMMER ACTUATING MECHANISM

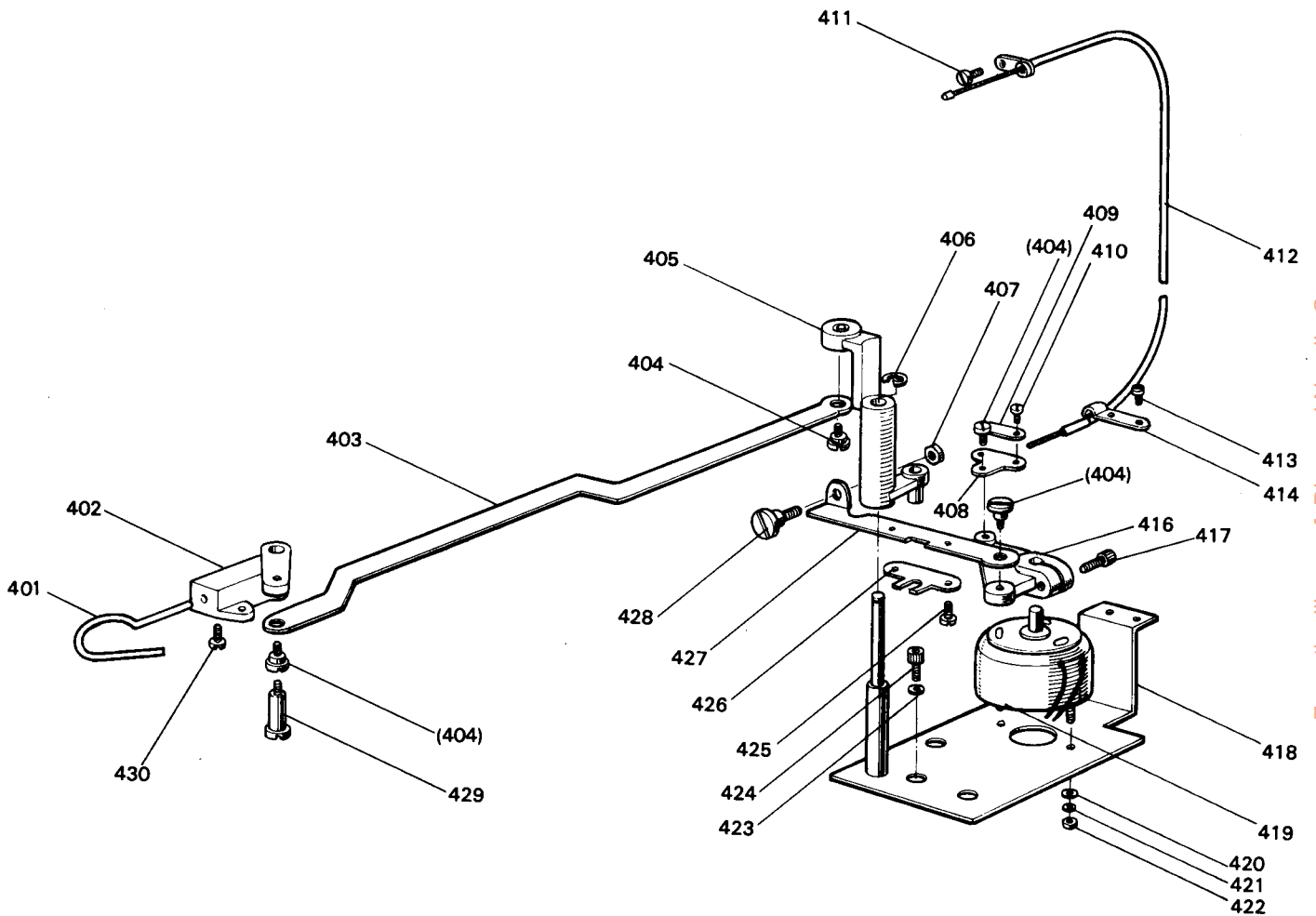

From the library of: Diamond Needle Corp

7 ピッカー及び糸切り作動機構

PICKER & THREAD TRIMMER ACTUATING MECHANISM

Fig. No.	部品コード Parts. No.	部 品 名	Parts name	使用 個数 Amt Req.	資 材 コード Ref. No.
401	MF 90A0 182	ピ ッ カ ー	Picker	1	W487057H01
402	MF 90A0 603	ピッカー取付台	Picker bracket	1	W487056H01
403	MG 44B0 427	ピッカー作動リンク	Picker actuating link	1	W488449H01
404	M9 1127 015	段付平ネジ	Screw	4	W487061H01
405	MF 90A0 392	ピッカー駆動腕	Picker driving crank	1	W487094G01
406	M9 0514 065	E形止メ輪 5	E-type stop ring 5	1	S922N210P50
407	M9 1620 045	ナ ッ ト ¼(40)	Nut ¼ (40)	1	W482843H01
408	MF 90A0 361	掛 ケ 金	Bracket	1	W487072H01
409	MF 36A0 750	ブ ッ シ ュ	Holder	1	W502917H01
410	M9 0802 002	平 ネ ジ ⅛(44)×7	Screw ⅛ (44)×7	2	W501083H01
411	M9 1110 002	平 ネ ジ ¼(40)×8	Screw ¼ (40)×8	1	W500294H01
412	MS 02E0 746	フレキシブルワイヤ	Flexible wire	1	A140D232H01
413	M9 1109 002	平 ネ ジ ¼(40)×7	Screw ¼ (40)×7	2	W500511H01
414	MF 90A0 780	ホ ル ダ	Holder	1	W487067H01
415					
416	MF 90A0 430	作 動 腕	Crank	1	W487069H02
417	M9 5003 021	六角穴付ボルト M5×0.8×12	Screw M5×0.8×12	1	S903N210P12
418	MS 02A4 601	ソレノイド取付板	Solenoid braket	1	A140D228G01
419	M9 0003 095	ロータリソレノイド	Rotary solenoid	1	A190D016P01
420	M9 0451 050	小 座 金 4	Washer 4	2	S913N010P04
421	M9 0401 053	バ ネ 座 金 4	Spring washer 4	2	S913N210P04
422	M9 1003 045	ナ ッ ト M4×0.7	Nut M4×0.7	2	S910N010P04
423	M9 0104 053	バ ネ 座 金 6	Spring washer 6	2	S913N210P06
424	M9 6006 021	六角穴付ボルト M6×12	Screw M6×12	2	S903N211P12
425	M9 0922 002	平 ネ ジ ¼(40)×8	Screw ¼ (40)×8	2	W464016H01
426	MF 90A0 341	ピッカー駆動板	Picker drive plate	1	W487044H01
427	MF 90A0 910	リ ン ク	Link	1	W487043H01
428	M9 1684 015	段付平ネジ	Screw	1	W487045H01
429	M9 1220 015	段付平ネジ	Screw	1	W487058H01
430	M9 0908 003	丸 平 ネ ジ ¼(40)×5	Screw ¼ (40)×5	2	W502003H01

From the library of: Diamond Data Co., Ltd.

8 Y-Y 機構 X X-Y TABLE MECHANISM

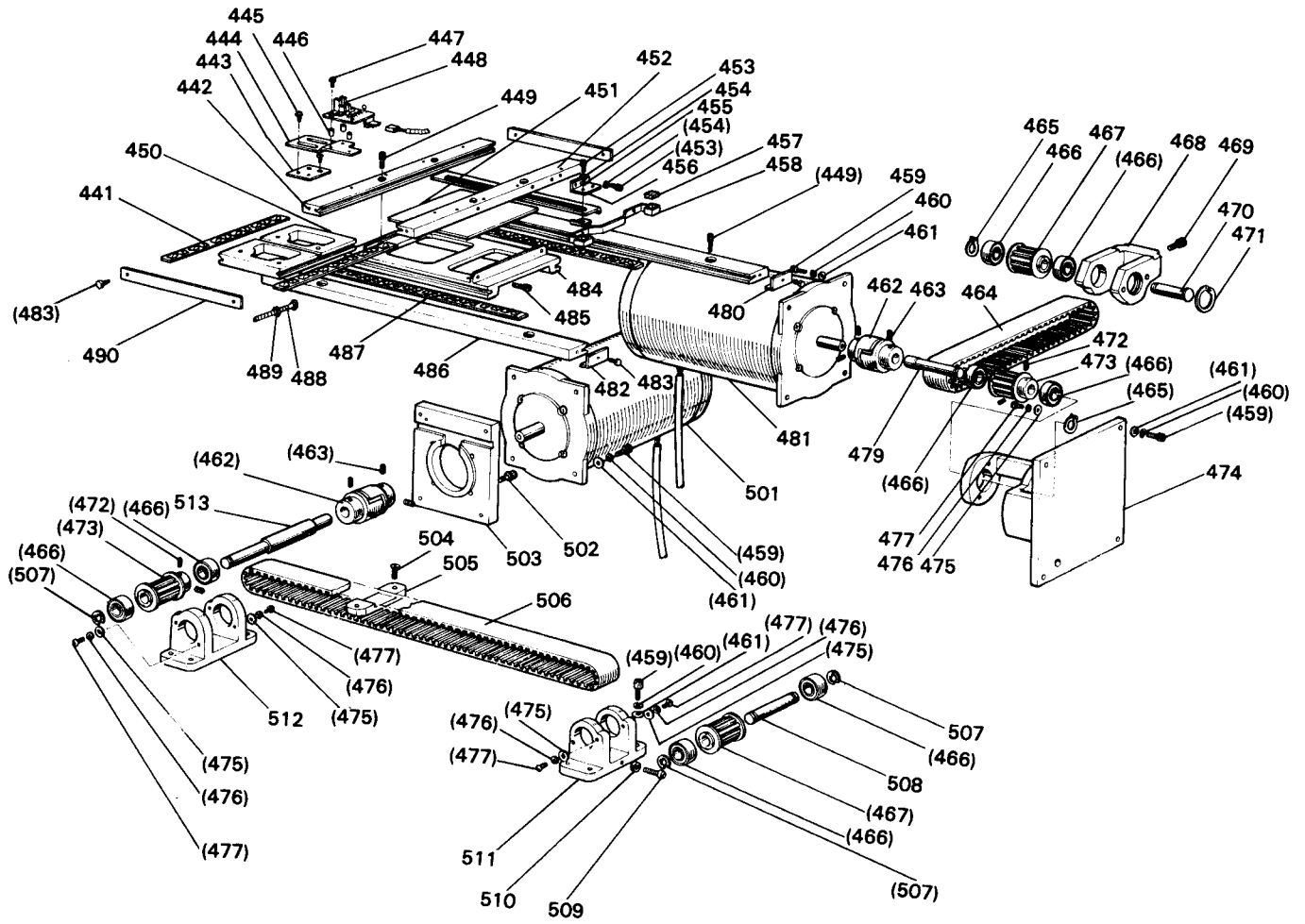

From the library of: Diamond Needle Corp

8 X-Y 機構 X-Y TABLE MECHANISM

Fig. No.	部品コード Parts. No.	部 品 名	Parts name	使用 個数 Amt. Req.	資 材 コー ド Ref. No.
441	MS02A0 972	ローラゲージ (Y)	Roller cage (Y)	2	A190D040P01
442	MS 02A1 957	Y軸固定レース (左)	Fixed race (left)	1	A140D292H03
443	MS 02B2 601	取 付 板	Adapter	1	A140D208H01
444	MS 02A0 408	X 位置検出台	Detector holder	1	A140D307H01
445	M9 0420 037	SW,PW,Pナベネジ M4×0.7×8	Screw M4×0.7×8	2	S902N034P08
446	ML 35A0 426	サポ ー ト	Supporter	3	W488951H01
447	M9 0304 037	SW,PW,Pナベネジ M3×0.5×12	Screw M3×0.5×12	3	S902N032P12
448	M9 1102 096	プリント板組立 (X)	Control circuit unit (X)	1	TE703P195G10
449	M9 4003 021	六角穴付ボルト M4×0.7×12	Bolt M4×0.7×12	8	S903N219P36
450	MS 02B1 957	Y軸移動レース	Movable race (Y)	1	A130C147H03
451	MS 02A1 476	ス ペ ー サ	Spacer	1	A140D451H01
452	MS 02A2 957	Y軸固定レース (右)	Fixed race (right)	1	A140D291H03
453	M9 3003 021	六角穴付ボルト M3×0.5×6	Bolt M3×0.5×6	6	S903N219P03
454	M9 0305 053	バネ座金 3	Spring washer 3	6	S913N210P02
455	M9 0311 050	小 座 金 3	Washer 3	2	S913N010P02
456	MS 02B3 601	取 付 板	Adapter	2	A140D304H02
457	MS 02A0 740	フ ェ ル ト	Felt	2	A140D560H01
458	MS 02A0 426	フェルト支エ	Holder	1	A140D559H01
459	M9 5001 021	六角穴付ボルト M5×0.5×16	Bolt M5×0.8×16	16	S903N210P16
460	M9 0501 053	バネ座金 5	Spring washer 5	20	S913N210P05
461	M9 0552 050	小 座 金 5	Washer 5	16	S913N010P05
462	MS 02A0 364	カップリング	Coupling	2	A140D299G01
463	M9 5002 020	六角穴付止メネジ M5×0.8×6	Screw M5×0.8×6	8	S901N310P06
464	MS 02A1 523	歯形ベルト (Y)	Cog belt (Y)	1	A190D012P01
465	M9 0311 065	軸用C形止メ輪 10	C-type retaining ring 10	2	S922N010P10
466	MS 02A2 456	シールドボールベアリング	Bearing	8	S860N003P10
467	MS 02A1 767	ベ ル ト 車	Cog pulley	2	A140D297H01
468	MS 02A0 758	ブ ラ ケ ッ ト	Bracket	1	A130C125H02
469	M9 5011 021	六角穴付ボルト M5×0.8×25	Bolt M5×0.8×25	1	S903N210P25
470	MS 02A0 454	軸	shaft	1	A140D303H01
471	M9 0326 065	穴用C形止メ輪 26	C-type retaining ring 26	1	S922N110P26
472	M9 5004 020	六角穴付止メネジ M5×0.8×8	Bolt M5×0.8×8	4	S901N310P08
473	MS 02A0 767	ベ ル ト 車	Cog pulley	2	A140D298H01
474	MS 02A1 758	ブ ラ ケ ッ ト	Bracket	1	A130C123H03
475	M9 0450 050	ミガキ座金 4	Washer 4	10	S913N040P04
476	M9 0401 053	バネ座金 4	Spring washer 4	10	S913N210P04
477	M9 0406 037	P ナベネジ M4×0.7×6	Screw M4×0.7×6	10	S900N014P06
478					
479	MS 02A1 390	Y 駆 動 軸	Shaft	1	A140D302H01
480	MS 02A4 477	ス ト ッ パ	Stopper	2	A140D293H03
481	M9 5005 095	ステッピングモータ (Y軸)	Motor complete (Y)	1	A130C170G02
482	MS 02A3 477	ス ト ッ パ	Stoper	2	A140D293H02
483	M9 1003 022	ボ ル ト M4×0.7×8	Bolt M4×0.7×8	8	S903N089P34
484	MS 02B0 957	X 移動レース	Movable race (X)	1	A130C148H03
485	M9 5013 021	六角穴付ボルト M3×0.5×10	Bolt M3×0.5×10	2	S903N219P05
486	MS 02A0 957	X軸固定レース	Fixed race (X)	2	A140D290H03
487	MS 02A1 972	ローラゲージ (X)	Roller cage (X)	2	A190D039P01
488	M9 1004 022	ボ ル ト M4×0.7×40	Bolt M4×0.7×40	2	S903N019P40
489	M9 1003 045	ナ ッ ト M4×0.7	Nut M4×0.7	2	S910N010P04
490	MS 02A5 477	ス ト ッ パ	Stopper	2	A140D426H02
501	M9 5006 095	ステッピングモータ (X軸)	Motor complete (X)	1	A130C170G01
502	M9 5003 021	六角穴付ボルト M5×0.8×12	Bolt M5×0.8×12	4	S903N210P12
503	MS 02B4 601	モートル取付板	Motor adapter	1	A130C126H02
504	M9 4005 037	P サラネジ M4×0.7×8	Screw M4×0.7×8	2	S900N114P08
505	MS 02A0 778	ベルト押エ	Belt clamper (X)	1	A140D296H02
506	MS 02A0 523	歯形ベルト (X)	Cog belt (X)	1	A190D013P01
507	M9 0604 065	E 形 止 メ 輪 8	E-type retaining ring 8	3	S922N210P80
508	MS 02A1 454	軸	Shaft	1	A140D300H01
509	M9 0509 037	P ナベネジ M5×0.8×30	Screw M5×0.8×30	1	S900N015P30
510	M9 1373 045	ナ ッ ト M5×0.8	Nut M5×0.8	1	S910N010P05
511	ML 35A3 758	ブ ラ ケ ッ ト	Bracket	1	A130C122H01
512	ML 35A2 758	ブ ラ ケ ッ ト	Bracket	1	A130C121H01
513	MS 02 A0 390	X 駆 動 軸	Shaft	1	A140D301H01

9 外押工機構
WORK HOLDER MECHANISM

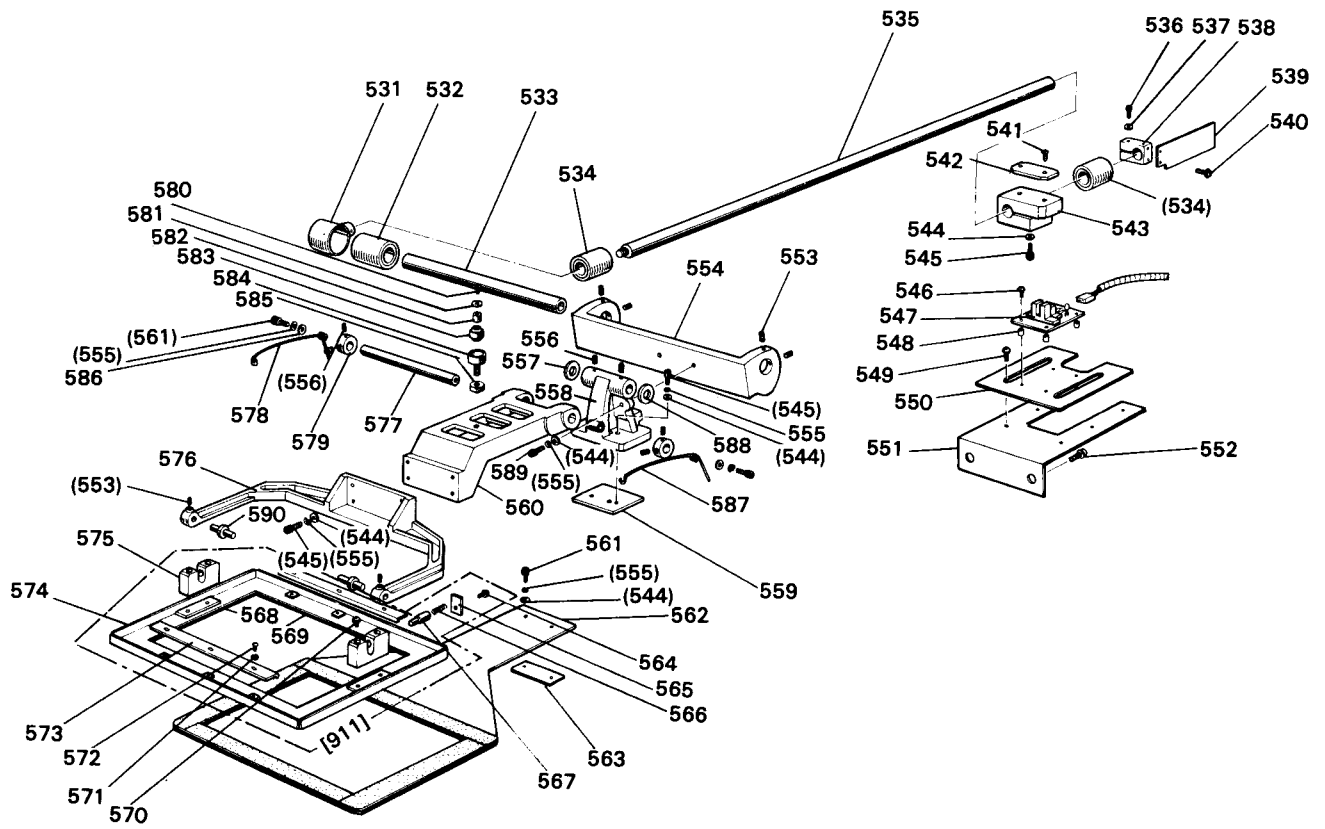

From the library of: Diamond Needle Corp

9 外押工機構 WORK HOLDER MECHANISM

Fig. No.	部品コード Parts No.	部品名	Parts name	使用 個数 Amt. Req.	資材コード Ref. No.
531	MS 02A0 456	軸受ハウジング	Bearing housing	1	A140D456G02
532	MS 02A0 628	L M ボール	Bearing	1	A190D035P01
533	MS 02A4 454	軸	Shaft	1	A140D457H02
534	MS 02A1 628	L M ボール	Bearing	2	P980017X01
535	MS 02A2 390	Y 駆動軸	Shaft	1	A140D289H02
536	M9 4002 021	六角穴付ボルト M4×0.7×16	Bolt M4×0.7×16	1	S903N219P38
537	M9 0451 050	小座金 4	Washer	1	S913N010P04
538	MS 02A4 603	Y軸検出板取付台	Detector plate holder (Y)	1	A140D960H02
539	MS 02A2 407	Y軸検出板	Detector plate (Y)	1	A140D959H02
540	M9 0420 037	SW,PW,Pナベネジ M4×0.7×8	Screw M4×0.7×8	2	S902N034P08
541	M9 4001 037	Pサラネジ M4×0.7×12	Screw M4×0.7×12	2	S900N114P12
542	MS 02A0 778	ベルト押エ	Belt clamber (Y)	1	A140D296H01
543	MS 02A0 781	Yベルト台	Belt holder (Y)	1	A140D213H02
544	M9 0552 050	小座金 5	Washer 5	11	S913N010P05
545	M9 5001 021	六角穴付ボルト M5×0.8×16	Bolt M5×0.8×16	7	S903N210P16
546	M9 0304 037	SW,PW,Pナベネジ M3×0.5×12	Screw M3×0.5×12	3	S902N032P12
547	M9 5002 096	プリント板組立 (Y)	Control circuit unit (Y)	1	TE703P196G10
548	ML 35A0 426	サポート	Supporter	3	W488951H01
549	M9 0409 037	SW,PW,Pナベネジ M4×0.7×10	Screw M4×0.7×10	2	S902N034P10
550	MS 02A2 408	Y軸検出台	Detector holder (Y)	1	A140D957H01
551	MS 02B5 601	取付板	Adapter	1	A140D958H01
552	M9 0408 037	SW,PW,Pナベネジ M4×0.7×12	Screw M4×0.7×12	2	S902N034P12
553	M9 1353 020	六角穴付止メネジ M4×0.7×6	Screw M4×0.7×6	6	S901N319P11
554	MS 02A0 455	軸支エ	Shaft holder	1	A130C221H01
555	M9 0501 053	バネ座金 5	Washer 5	10	S913N210P05
556	M9 5002 020	六角穴付止メネジ M5×0.8×6	Screw M5×0.8×6	6	S901N310P06
557	M9 1006 050	座金 (t=1.5)	Washer (t=1.5)	1	A140D282H01
558	MS 02A0 308	押エ台	Clamp bracket	1	A130C119H01
559	MS 02A2 476	スペーサ	Spacer	1	A140D450H01
560	MS 02A1 273	押エ腕 (II)	Clamp adapter (II)	1	A130C118H01
561	M9 5003 021	六角穴付ボルト M5×0.8×12	Bolt M5×0.8×12	4	S903N210P12
562	MS 02E0 272	送り板 (組)	Feed plate complete	1	A140D349G01
563	MS 02A3 476	スペーサ	Spacer	1	A140D569H01
911	MS 02E0 105	外押エ (組)	Clamp frame complete	1	A130C257G02
564	M9 0338 037	SW,PW,Pナベネジ M3×0.5×6	Screw M3×0.5×6	2	S902N012P06
565	MS 02B0 257	押エ板	Adapter	2	A140D354H01
566	MN 10A0 572	バネ	Spring	2	W501035H01
567	M9 0611 060	ピン	Pin	2	A140D353H01
568	MS 02A0 691	パッキン	Clamp pad	2	A140D287H01
569	MS 02A1 691	パッキン	Clamp pad	2	A140D287H02
570	M9 0409 037	SW,PW,Pナベネジ M4×0.7×10	Screw M4×0.7×10	6	S902N034P10
571	M9 0451 050	小座金 4	Washer 4	6	S913N010P04
572	M9 0406 037	Pナベネジ M4×0.7×6	Screw M4×0.7×6	6	S900N014P06
573	MS 02B6 601	取付板	Adapter	2	A140D286H01
574	MS 02A2 105	外押エ	Cramp frame	1	A130C143G01
575	MS 02E0 426	支エ	Supporter	2	A140D352H01
576	MS 02A0 273	押エ腕 (I)	Clamp adapter (I)	1	A130C117H01
577	MS 02A3 454	軸	Shaft	1	A140D281H02
578	MS 02A0 729	ヒネリバネ (左)	Spring (left)	1	A140D285H02
579	MS 02A1 352	カラ	Collar	2	A140D283H01
580	M9 4007 037	Pサラネジ M3×0.5×8	Screw M3×0.5×8	1	S900N112P08
581	MS 01A0 457	摺動子	Slider	1	W488805H01
582	MS 02A3 456	球面滑り軸受	Bearing	1	A190D011P01
583	MS 02A0 457	摺動子受ケ	Holder	1	A140D279H01
584	M9 3001 030	特殊ネジ	Special screw	1	A140D278H01
585	M9 2511 045	止メナット M10	Nut M10	1	S910N070P10
586	M9 0550 050	ミガキ座金 5	Washer 5	2	S913N040P05
587	MS 02A1 729	ヒネリバネ (右)	Spring (right)	1	A140D284H02
588	M9 1007 050	座金 (t=1.65)	Washer (t=1.65)	1	A140D282H03
589	M9 5014 021	六角穴付ボルト M5×0.8×14	Bolt M5×0.8×14	2	S903N210P14
590	MS 02A2 454	押エ軸	Clamp stud	2	A140D275H01

10 外押工駆動機構
 WORK HOLDER DRIVING MECHANISM

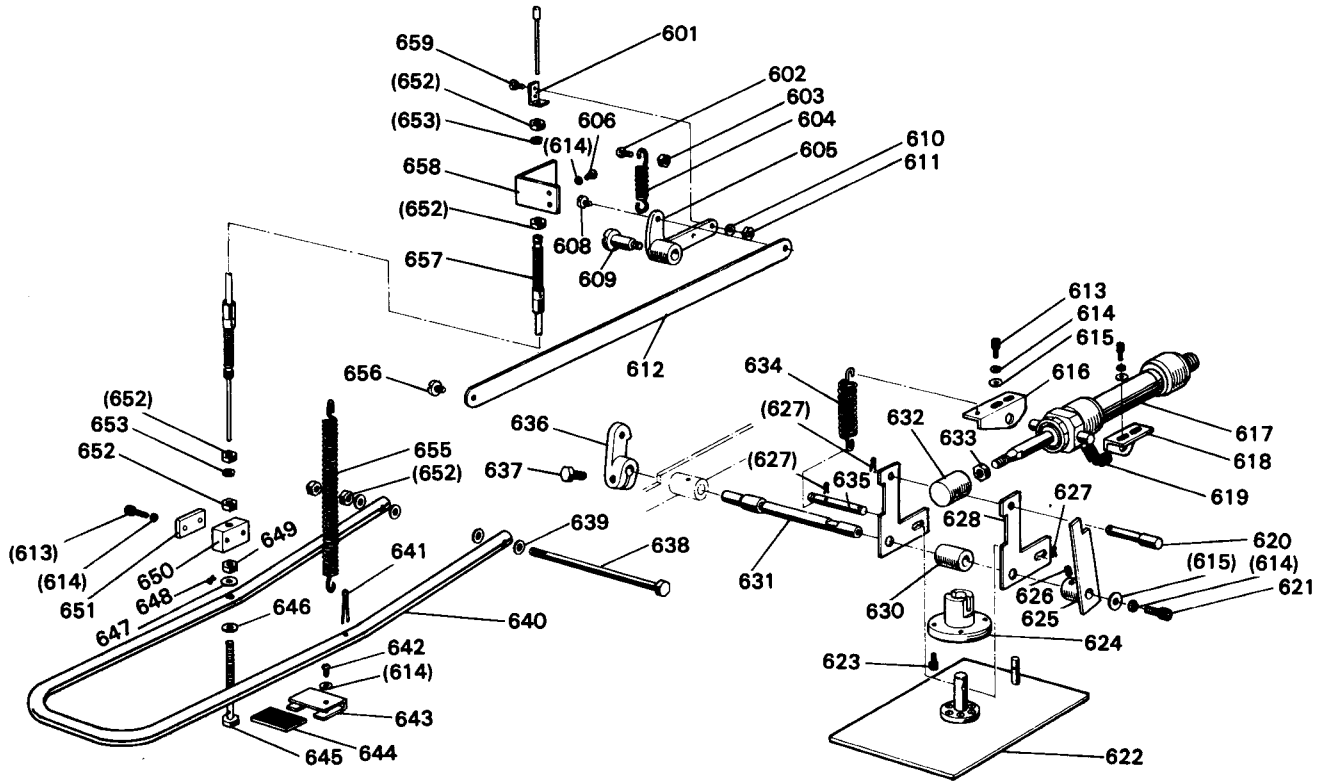

From the library of: Diamond Needle Corp

10 外押エ駆動機構

WORK HOLDER DRIVING MECHANISM

Fig. No.	部品コード Parts No.	部 品 名	Parts name	使用 個数 Amt. Req.	資 材 コード Ref. No.
601	MS 02A0 361	カ ケ 金	Bracket	1	A140D273H01
602	M9 0440 037	P ナ ベ ネ ジ M4×0.7×16	Screw M4×0.7×16	1	S900N014P16
603	M9 1003 045	ナ ッ ト M4×0.7	Nut M4×0.7	1	S910N010P04
604	MF 70A0 572	ツルマキバネ	Spring	1	W481478H01
605	MS 01E0 763	ベルクランク	Bell crank	1	W488856G01
606	M9 0508 037	P ナ ベ ネ ジ M5×0.8×10	Screw M5×0.8×10	2	S900N015P10
607					
608	M9 1219 015	平 ネ ジ 段 付 3/16(28)	Screw 3/16 (28)	1	W481460H01
609	M9 2001 016	丸 平 ネ ジ 段 付 5/16(24)	Screw 5/16 (24)	1	B503843H01
610	M9 0550 050	小 座 金 5	Washer 5	1	S913N040P05
611	M9 1205 045	ナ ッ ト 3/16(28)	Nut 3/16 (28)	1	W501097H01
612	MS 02A0 910	リ ン ク	Link	1	A140D272H01
613	M9 5001 021	六角穴付ボルト M5×0.8×16	Bolt M5×0.8×16	6	S903N210P16
614	M9 0501 053	バ ネ 座 金 5	Washer 5	11	S913N210P05
615	M9 0552 050	小 座 金 5	Washer 5	5	S913N010P05
616	MS 02A2 601	取 付 足 (左)	Adapter	1	A140D258H02
617	MS 02A2 434	エヤシリンダ	Air cylinder	1	A190N011P01
618	MS 02A3 601	取 付 足 (右)	Adapter	1	A140D257H02
619	MS 02A5 571	ワンタッチ継手	Air fitting	1	A190N012P01
620	M9 0806 060	ピ ン	Pin	1	A140D262H01
621	M9 5009 021	六角穴付ボルト M5×0.8×8	Bolt M5×0.8×8	1	S903N210P08
622	MS 02E0 257	押 エ 板 (組)	Presser plate complete	1	A130C140G01
623	M9 4011 021	六角穴付ボルト M4×0.7×8	Bolt M4×0.7×8	4	S903N219P34
624	MS 02A1 456	軸 受	Bushing	1	A130C142G01
625	MS 02A0 392	駆 動 腕	Crank	1	A140D261G01
626	M9 6003 020	六角穴付止メネジ M6×6	Screw M6×6	1	S901N311P06
627	M9 0105 062	スナップピン	Snap pin	3	S921N020P06
628	MS 02A2 273	押エクランク	Clamp driving crank	2	A140D254H01
629					
630	MS 02A0 352	カ ラ	Collor	1	A140D260H01
631	MS 02A5 454	軸	Shaft	1	A140D259H02
632	MS 02A0 571	継 手	Connector	1	A140D256H01
633	M9 2008 045	ナ ッ ト M8(細目)	Nut M8	1	S910N010P08
634	MS 02A3 572	ツルマキバネ	Spring	1	A140D263H02
635	M9 0612 060	ピ ン	Pin	1	A140D264H01
636	MS 01A1 228	腕	Crank	1	W488861H01
637	M9 1603 022	ボ ル ト 1/4(40)×13	Bolt 1/4 (40)×13	1	W468547H01
638	M9 2052 022	ボ ル ト M8×155	Bolt M8×155	1	S903N012P79
639	M9 0816 050	ミ ガ キ 座 金 8	Washer 8	4	S913N040P08
640	MS 02A1 748	ペ ダ ル	Pedal	1	A130C177H01
641	M9 0106 062	割 ビ ン 3×40	Pin 3×40	1	S921N004P40
642	M9 0504 037	P ナ ベ ネ ジ M5×0.8×6	Screw M5×0.8×6	2	S900N015P08
643	MS 02A2 226	受 金	Holder	1	A140D370H02
644	MS 02A2 416	緩 衝 板	Ruber cushion	2	A140D371H01
645	M9 1103 031	特 殊 ボ ル ト	Special bolt	1	A130C178G01
646	M9 0601 050	ミ ガ キ 座 金 6	Washer 6	1	S913N040P06
647	M9 0603 050	座 金 6	Washer 6	1	W467215H01
648	M9 0107 062	割 ビ ン 1.6×10	Pin 1.6×10	1	S921N001P10
649	M9 1575 045	ナ ッ ト M6	Nut M6	1	S910N010P06
650	MS 02B7 601	取 付 板 (下)	Adapter	1	A140D365H01
651	MS 02B1 257	押 エ 板	Clamp	1	A140D366H01
652	M9 2008 045	ナ ッ ト M8	Nut M8	4	S910N010P08
653	M9 0802 053	バ ネ 座 金 8	Spring Washer 8	2	S913N210P08
654					
655	MS 02A0 572	ツルマキバネ	Spring	1	A140D368H01
656	M9 1251 015	平 ネ ジ 段 付 3/16(32)	Screw 3/16 (32)	1	B509180H01
657	MS 02A0 746	フレキシブルワイヤ	Flexible wire	1	A140D369H02
658	MS 02A1 601	取 付 板 (上)	Adapter	1	A140D274H01
659	M9 1130 015	平 ネ ジ 段 付 1/4(40)	Screw 1/4 (40)	1	W488841H01

11 ワイパー、スイッチ機構
WIPER & SWITCH MECHANISM

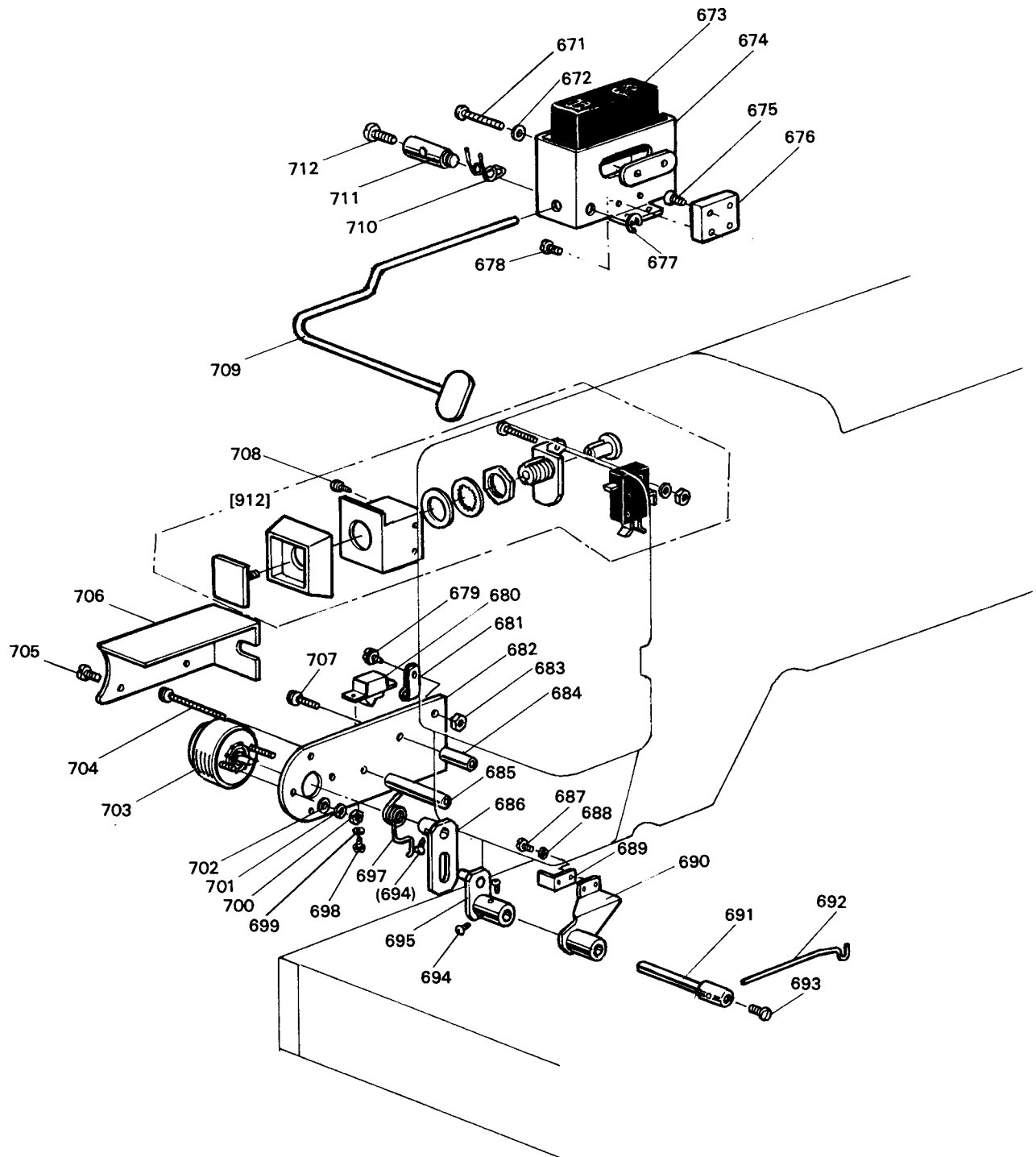

From the library of: Diamond Needle Corp

11 ワイパー、スイッチ機構 WIPER & SWITCH MECHANISM

Fig. No.	部品コード Parts No.	部品名	Parts name	使用 個数 Amt. Req.	資材コード Ref. No.
671	M9 0412 037	P ナベネジ M4×0.7×30	Screw M4×0.7×30	2	S900N014P30
672	M9 0409 050	ミガキ座金 4	Washer 4	2	S913N040P04
673	M9 0204 099	リミットスイッチ	Micro switch	1	P422111X01
674	MS 02E0 485	スイッチ箱	Switch box	1	A140D250G01
675	M9 4001 037	P サラネジ M4×0.7×12	Screw M4×0.7×12	2	S900N114P12
676	MS 02A5 601	取付板	Switch adapter	1	A140D246H01
677	M9 0505 065	E形止メ輪 5	E-type rataing ring 5	1	S922N210P05
678	M9 0408 037	SW,PW,Pナベネジ M4×0.7×12	Screw M4×0.7×12	2	S902N034P12
679	M9 0420 037	SW,PW,Pナベネジ M4×0.7×8	Screw M4×0.7×8	1	S902N034P08
680	MF 40E2 484	波動スイッチ	Toggle switch	1	P909001X01
681	M9 4003 099	ナイロンクリップ HP-3N	Cord holder	1	S945N220P03
682	MS 02A0 509	ソレノイド台	Solenoid adapter	1	A130C136H01
683	M9 1003 045	ナット M4×0.7	Nut M4×0.7	1	S910N010P04
684	MS 02A4 476	スペーサ (短)	Spacer	1	A140D249H02
685	MF 90A0 476	スペーサ (長)	Spacer	1	W487083H01
686	MS 02E0 983	ワイパー駆動腕	Driving crank	1	A140D241G01
687	M9 0410 037	P ナベネジ M4×0.7×8	Screw M4×0.7×8	2	S900N014P08
688	M9 0401 053	バネ座金 4	Spring washer 4	2	S913N210P04
689	MS 02A1 477	ストッパ	Stopper	1	A140D446H01
690	MS 02E0 982	ワイパー台	Wiper adapter	1	A140D238G02
691	MF 40A0 530	ワイパー軸	Wiper shaft	1	W480482H01
692	MS 02A0 980	ワイパー	Wiper	1	A140D237H01
693	M9 0806 002	平ネジ 1/8(44)×6	Screw 1/8 (44)×6	1	B508857H01
694	M9 0802 003	丸平ネジ 1/8(44)×4.5	Screw 1/8 (44)×4.5	4	W502074H01
695	MS 02E0 981	ワイパー腕	Wiper crank	1	A140D244G01
696					
697	MS 02A4 729	ヒネリバネ	Spring	1	A140D247H01
698	M9 0336 037	P ナベネジ M3×0.5×6	Screw M3×0.5×6	2	S900N012P06
699	M9 0311 050	小座金 3	Washer 3	2	S913N010P02
700	M9 0874 045	ナット M3×0.5	Nut M3	2	S910N010P02
701	M9 0305 053	バネ座金 3	Spring washer 3	2	S913N210P02
702	M9 0311 050	小座金 3	Washer 3	2	S913N010P02
703	M9 0004 095	ロータリソレノイド	Rotary solenoid	1	A190D017P01
704	M9 0415 037	SW,PW,Pナベネジ M4×0.7×32	Screw M4×0.7×32	1	S900N014P32
705	M9 0909 003	丸平ネジ 3/8(40)×6	Screw 3/8 (40)×6	2	W501901H01
706	MS 02A1 339	カバー板	Cover	1	A140D248H01
707	M9 0416 037	SW,PW,Pナベネジ M4×0.7×20	Screw M4×0.7×20	1	S900N014P20
912	MS 02A0 484	押ボタンスイッチ (組)	Switch complete	1	A190D015P01
708	M9 0408 037	SW,PW,Pナベネジ M4×0.7×12	Screw M4×0.7×12	2	S902N034P12
709	MS 02E0 532	レバ (組)	Lever complete	1	A130C137G02
710	MF 40A0 729	ヒネリバネ	Spring	1	W476467H01
711	MF 40A1 530	段付軸	Shaft	1	W476465H01
712	M9 1117 002	丸平ネジ 3/8(40)×11.4	Screw 3/8 (40)×11.4	1	B503844H01

12 給油機構
OIL LUBRICATION MECHANISM

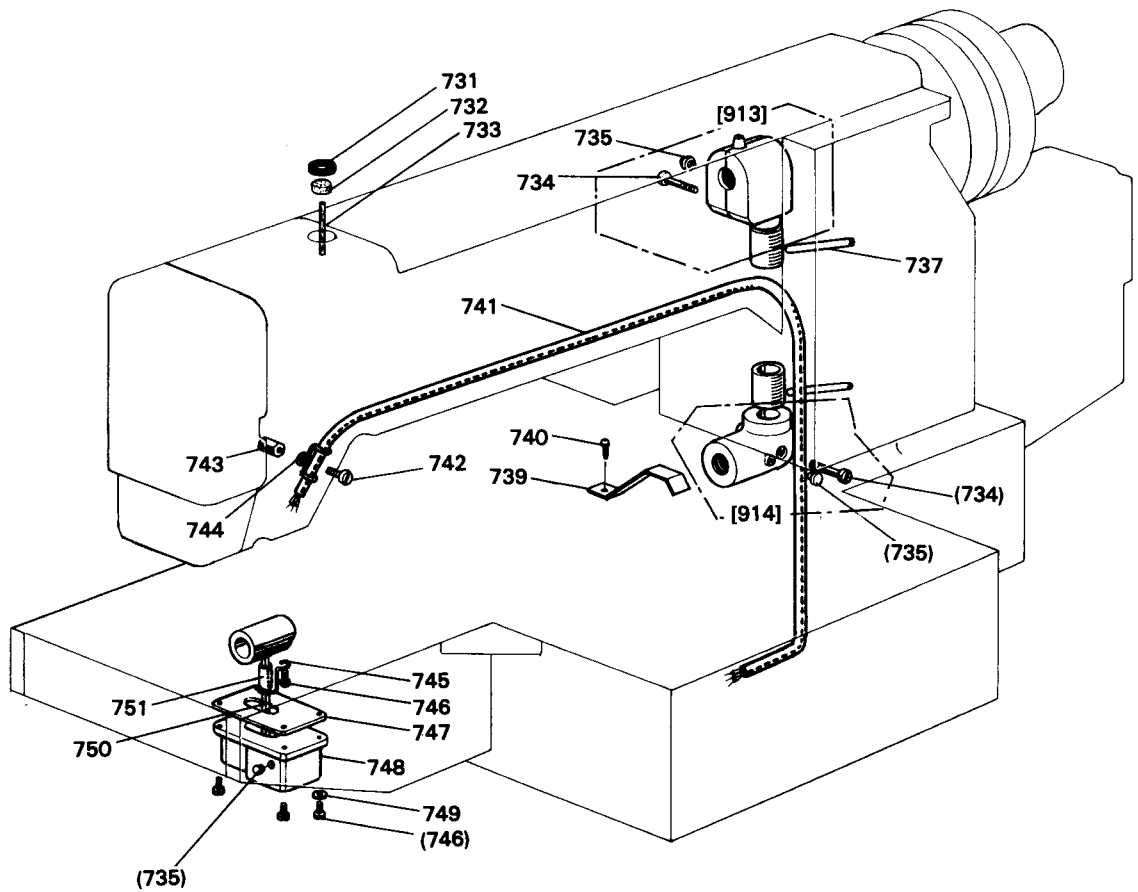

From the library of: Diamond Needle Corp

12 給油機構 OIL LUBRICATION MECHANISM

Fig. No.	部品コード Parts. No.	部 品 名	Parts name	使用 個数 Amt. Req.	資 材 コー ド Ref. No.
731	MG 41B0 742	油 蓋	Cap for oiler	1	W471448H01
732	MF 60A5 740	フ ェ ル ト	Felt	1	W500906H01
733	MF 10E2 148	油 紐 $\phi 2.5 \times 35$	Oil wick $\phi 2.5 \times 35$	1	W464023H01
913	MF 60E1 711	歯 車 箱 上 (組)	Arm shaft bevel gear box complete	1	W482329G02
734	M9 0510 037	P ナ ベ ネジ $M5 \times 0.8 \times 12$	Screw $M5 \times 12$	2	S900N015P12
735	M9 0570 080	ゴ ム 栓	Rubber plug	3	W502078H01
736					
737	MS 02A0 688	バ イ プ	Pipe	2	A140D234H01
914	MG 41E0 712	歯 車 箱 下 (組)	Hook shaft bevel gear box complete	1	W481406G01
738					
739	MS 02A6 339	保 護 カ バ ー	Oil guard	1	A140D972H01
740	M9 0420 037	SW, PW, P ナ ベ ネジ $M4 \times 0.7 \times 8$	Screw $M4 \times 0.7 \times 8$	1	S902N034P08
741	MS 02E0 688	バ イ プ、ヒモ (組)	Oil pipe complete	1	A140D224G01
742	M9 1104 003	丸 平 ネジ $\frac{1}{4}(40) \times 12$	Screw $\frac{1}{4}(40) \times 12$	1	B509264H01
743	M9 1102 045	ナ ッ ト $\frac{1}{4}(40)$	Nut $\frac{1}{4}(40)$	1	W501097H01
744	MF 36A0 689	バ イ プ ホ ル ダ	Pipe holder	1	W470900H01
745	MG 43A0 689	センザイクバネ (パイプホルダ)	Pipe holder	1	W487120H02
746	M9 1101 004	ブ ラ マ イ ネ ジ $\frac{1}{4}(40) \times 8$	Screw $\frac{1}{4}(40) \times 8$	5	W466810H01
747	MG 42A1 691	ガ ス ケ ッ ト	Gasket for oil reservoir	1	W483469H02
748	MS 02A2 139	オ イ ル タ ン ク	Oil reservoir	1	A140D235G01
749	M9 0406 050	座 金	Washer	4	W470913H01
750	MN 10A5 740	フ ェ ル ト	Felt	1	W462954H01
751	MS 02A1 688	ビ ニ ール バ イ プ $6 \times 8 - 15$	Oil pipe $6 \times 8 - 15$	1	W462995H04

From the library of: Diamond Needle Corp

13 制御盤 CONTROL BOX

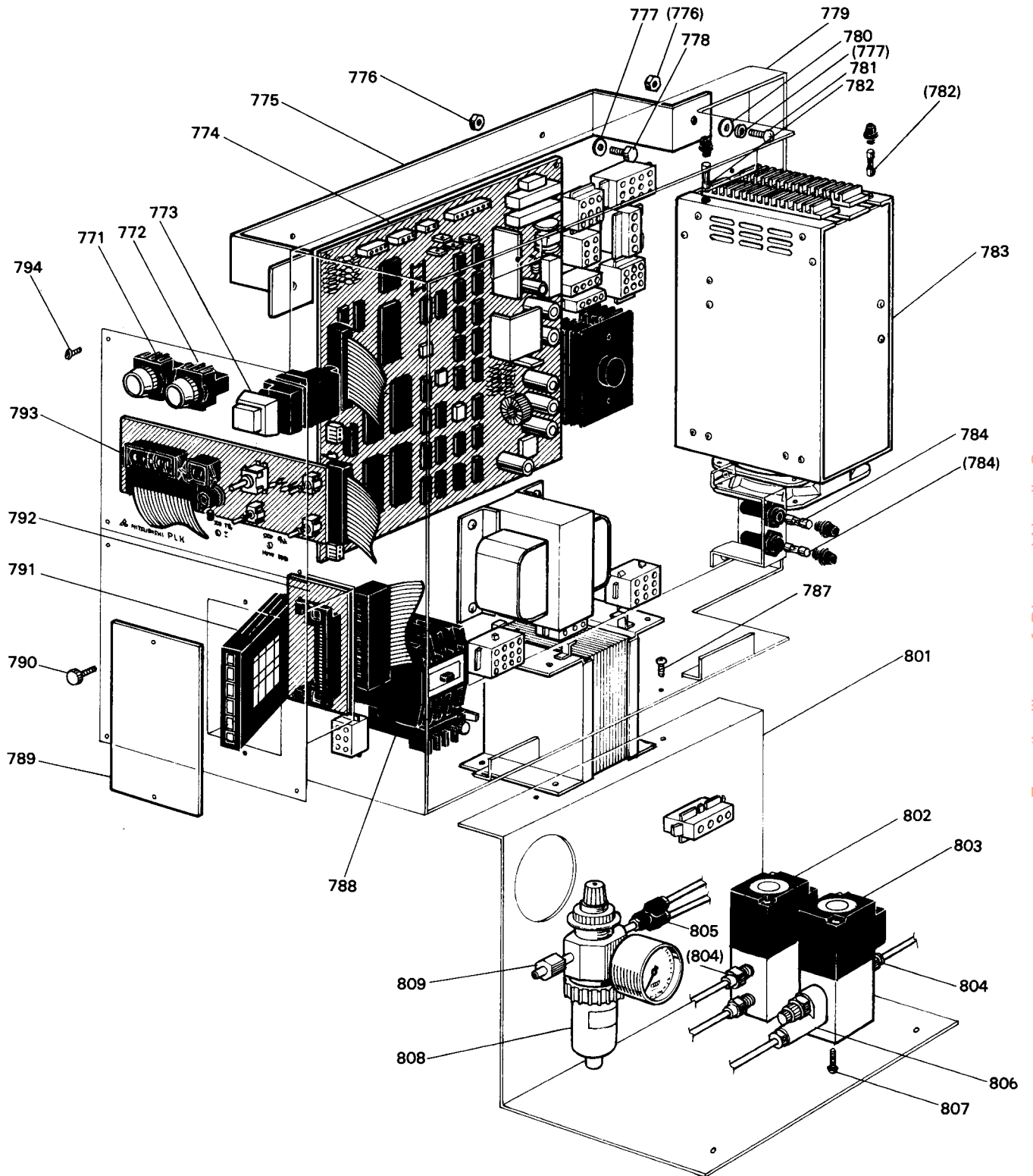

From the library of: Diamond Needle Corp

13 制 御 盤 CONTROL BOX

Fig. No.	部品コード Parts. No.	部 品 名	Parts name	使用 個数 Amt. Req.	資 材 コード Ref. No.
771	MS02E1484	押ボタンスイッチ	Switch	1	OR2-GR-1B
772	MS02E2484	押ボタンスイッチ	Switch	1	OR2-GG-1A
773	M90609099	表 示 灯	Pilot lamp	1	PA-2-SG-T1
774	M9 3001 096	プリント板組立 CPU	Control circuit unit (CPU)	1	TE703P197G10
775	MS 02B8 601	取 付 板	Adapter	1	A140D359H01
776	M9 2008 045	ナ ッ ト M8	Nut M8	6	S910N010P08
777	M9 0802 053	バ ネ 座 金 8	Spring washer 8	6	S913N210P08
778	M9 2053 022	U P ボ ル ト M8×20	Bolt M8×20	2	S903N412P20
779	MS 02E0 499	制 御 箱	Control box	1	E730A402G01
780	M9 0816 050	ミ ガ キ 座 金 8	Washer 8	4	S913N040P08
781	M9 2003 037	P ナ ベ ネ ジ M8×40	Screw M8×40	4	S900N018P40
782	M9 1002 091	ヒ ュ ー ズ 125V 5A	Fuse 125V 5A	2	S460N011P35
783	M9 1001 097	ステッピングモータドライバ	Stepping motor driver	1	PMM-CS-705
784	M9 1001 091	ヒ ュ ー ズ 125V 10A	Fuse 125V 10A	2	S460N011P36
785					
786					
787	M9 0511 037	SW,PW,Pナベネジ M5×0.8×8	Screw M5×0.8×8	4	S902N035P08
788	M9 1001 093	電 磁 接 触 器	Magnet switch	1	
789	M9 04A0 742	フ タ	Cover	1	E730D300H01
790	M9 1003 035	細首ツマミネジ M3×0.5×8	Screw M3×0.5×8	2	S901Z610H01
791	MV 30E0 718	PRM付カセットケース (組)(1000針用)	Cast case with PROM (for 1000 stitches)	1	TE730D001G10
792	M9 8001 096	プリント板組立 CST	Control circuit unit (CST)	1	TE703P187G10
793	M9 6001 096	プリント板組立 PAL	Control circuit unit (PAL)	1	TE703P198G10
794	M9 0410 037	P ナ ベ ネ ジ M4×0.7×8	Screw M4×0.7×8	6	S900N014P08
801	MS 02B9 601	取 付 板	Adapter	1	E730B401H01
802	M9 1004 093	電 磁 弁	Solenoid valve	1	050-4E1-01-70-DC24V
803	M9 1005 093	電 磁 弁	Solenoid valve	1	050-E1-01-DC24V
804	MS 05E2 571	ワンタッチ継手	Air fitting	4	TS4-01
805	MS 02A6 571	ワンタッチ継手	Air fitting	1	TBY4-01
806	M9 1001 090	スピードコントローラ	Speed controller	1	SS4-01NA
807					
808	M9 1002 090	F R ユ ニ ッ ト	Filter-regulator unit	1	FR150-01
809	MS 02A7 571	ワンタッチ継手	Air fitting	1	TS8-01

From the library of: Diana Needle Co.

14 筐 体
TABLE MECHANISM

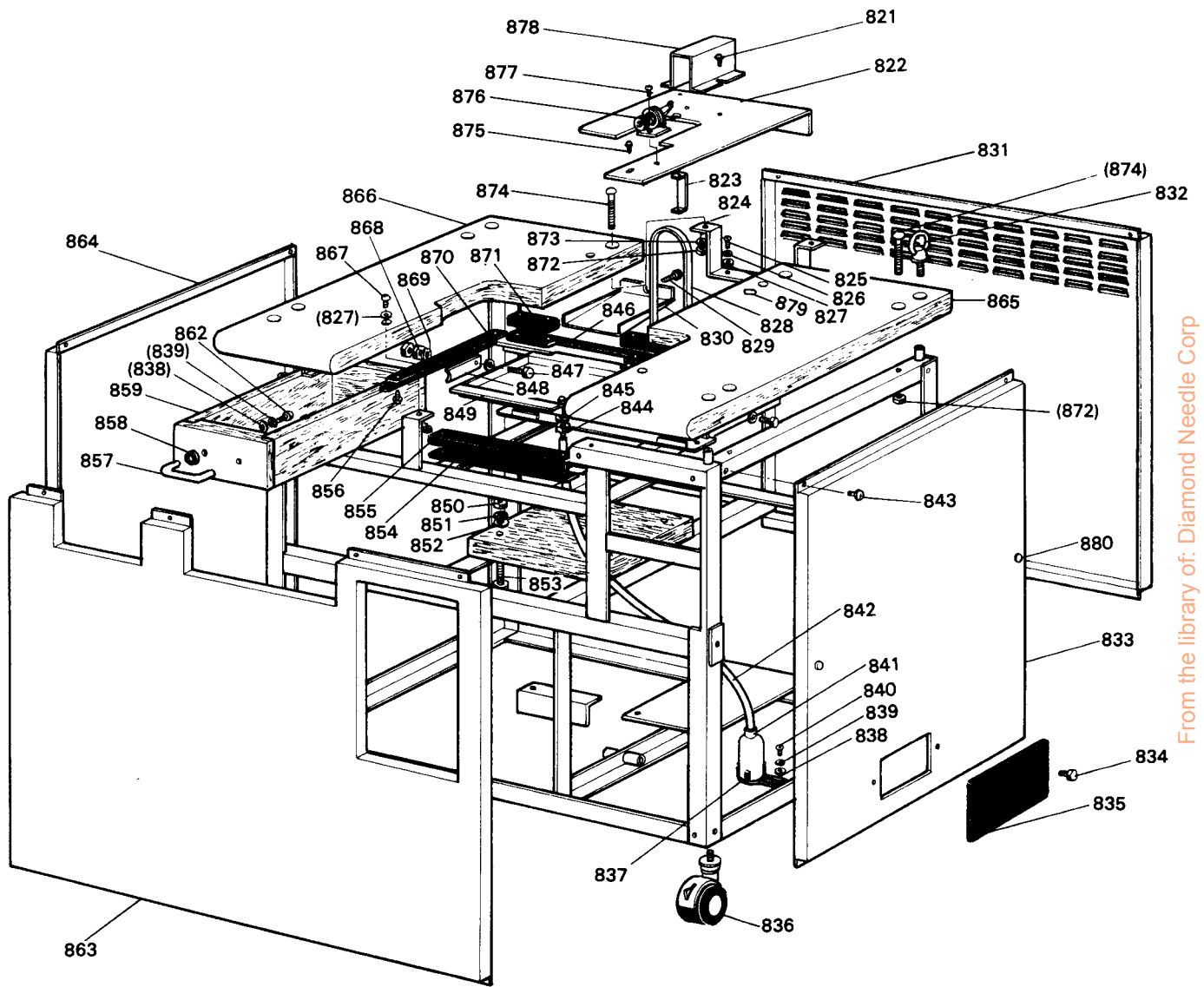

From the library of: Diamond Needle Corp

14 筐 体 TABLE MECHANISM

Fig. No.	部品コード Parts No.	部 品 名	Parts name	使用 個数 Amt. Req.	資 材 コー ド Ref. No.
821	M9 0420 037	SW,PW,Pナベネジ M4×0.7×8	Screw M4×0.7×8	2	S902N034P08
822	MS 02A2 339	カバ	Cover	1	A130C176H03
823	MS 02C0 601	取付板	Adapter	1	A140D961H01
824	MS 02C1 601	取付板	Adapter	1	A140D360H01
825	M9 0602 037	Pナベネジ M6×16	Screw M6×16	2	S900N016P16
826	M9 0104 053	バネ座金 6	Washer 6	2	S913N210P06
827	M9 0601 050	ミガキ座金 6	Washer 6	4	S913N040P06
828	MS 02A0 777	Vベルト M47	V belt M47	1	
829	M9 0511 037	SW,PW,Pナベネジ M5×0.8×8	Screw M5×0.8×8	1	S902N035P08
830	MS 02A1 139	オイルパン (II)	Oil pan (II)	1	A130C150H02
831	ML 35A7 339	カバー (後)	Cover	1	A120B036G01
832	M9 2210 031	アイボルト M10	Eye bolt M10	4	S904N310P10
833	ML 35A6 339	カバー (右)	Cover	1	A120B034G01
834	M9 1003 035	細首ツマミネジ M3×0.5×8	Screw M3×0.5×8	2	S901Z610H01
835	MS 02A0 742	フタ	Cover	1	E703D300H02
836	MS 02A2 972	キャスタ	Castor	4	MY6N12S
837	MF 20A0 131	油受台	Oil bottle holder	1	W453513H01
838	M9 0550 050	ミガキ座金 5	Washer 5	3	S913N040P05
839	M9 0501 053	バネ座金 5	Spring washer 5	3	S913N210P05
840	M9 0508 037	Pナベネジ M5×0.8×10	Screw M5×0.8×10	1	S900N015P10
841	MN 10A0 130	油ビン	Oil bottle	1	W346040H01
842	MS 02A2 688	パイプ	Pipe	1	A140D583H01
843	M9 0417 037	SW,PW,Pナベネジ(ミガキ座金付)M4×0.7×12	Screw M4×0.7×12	20	
844	M9 2001 047	特殊ネジ	Screw	1	W446050H01
845	MF 10A4 691	ガスケット	Gasket	1	W500812H01
846	MS 02A4 416	緩衝板	Ruber cushion	1	A140D320H01
847	M9 1012 022	UPボルト M10×30	Bolt M10×30	1	S903N413P30
848	MS 02A0 228	支エ腕	Head rest	1	A140D361H01
849	MS 02A0 139	オイルパン (I)	Oil pan (I)	1	A130C149G02
850	M9 2008 045	ナット M8	Nut M8	4	S910N010P08
851	M9 0802 053	バネ座金 8	Spring washer 8	4	S913N210P08
852	M9 0710 050	平座金 8	Washer 8	4	M904D908H01
853	M9 2055 022	UPボルト M8×60	Bolt M8×60	4	S903N412P60
854	MS 02A5 416	緩衝板	Ruber cushion	1	A140D320H02
855	MS 02A3 416	緩衝板	Ruber cushion	1	A140D319H01
856	M9 0303 041	P丸木ネジ φ3.5×16	Wood screw φ3.5×16	6	S908N104P16
857	MS 05A0 604	把手	Handle	1	A-42-C-7
858	M9 7006 050	座金	Washer	2	A-42-B-7
859	ML 35A0 719	引出し	Drawer	1	A130C175G01
860					
861					
862	M9 0512 037	Pナベネジ M5×35	Screw M5×35	2	S900N015P35
863	MS 02A7 339	カバー (前)	Cover	1	A120B033G02
864	MS 02A8 339	カバー (左)	Cover	1	A120B035H01
865	MS 02A3 595	天板 (左)	Table top	1	A130C174H03
866	MS 02A2 595	天板 (右)	Table top	1	A130C174H04
867	M9 0601 037	Pナベネジ M6×50	Screw	2	S900N016P50
868	M9 2511 045	ナット M10	Nut M10	2	S910N010P10
869	M9 1008 050	ミガキ座金 10	Washer 10	2	S913N040P10
870	ML 35A2 957	レール	Rail	2	A140D734H01
871	MS 02A4 416	緩衝板	Raber cushion	2	A140D321H01
872	M9 2008 045	ナット M8	Nut M8	6	S910N010P08
873	M9 0802 053	バネ座金 8	Spring washer 8	6	S913N210P08
874	M9 2055 022	取付ボルト M8×70	Bolt M8×70	6	M904Z514H03
875	M9 0409 037	SW,PW,Pナベネジ M4×0.7×10	Screw M4×0.7×10	1	S902N034P10
876	MS 02E0 173	糸案内 (組)	Thread guide complete	1	P979001X01
877	M9 1118 002	平ネジ ¼(40)×10	Screw ¼(40)×10	1	B509061H01
878	MS 02A9 339	Y検出器カバー	Detector cover	1	A130C410G01
879	M9 6502 009	E保護ブッシュ 28	Protective bushing 28	1	S935Z040H13
880	M9 1180 080	ゴム栓	Rubber plug	4	W502069H01

15 配線関係 WIRING CONNECTION MECHANISM

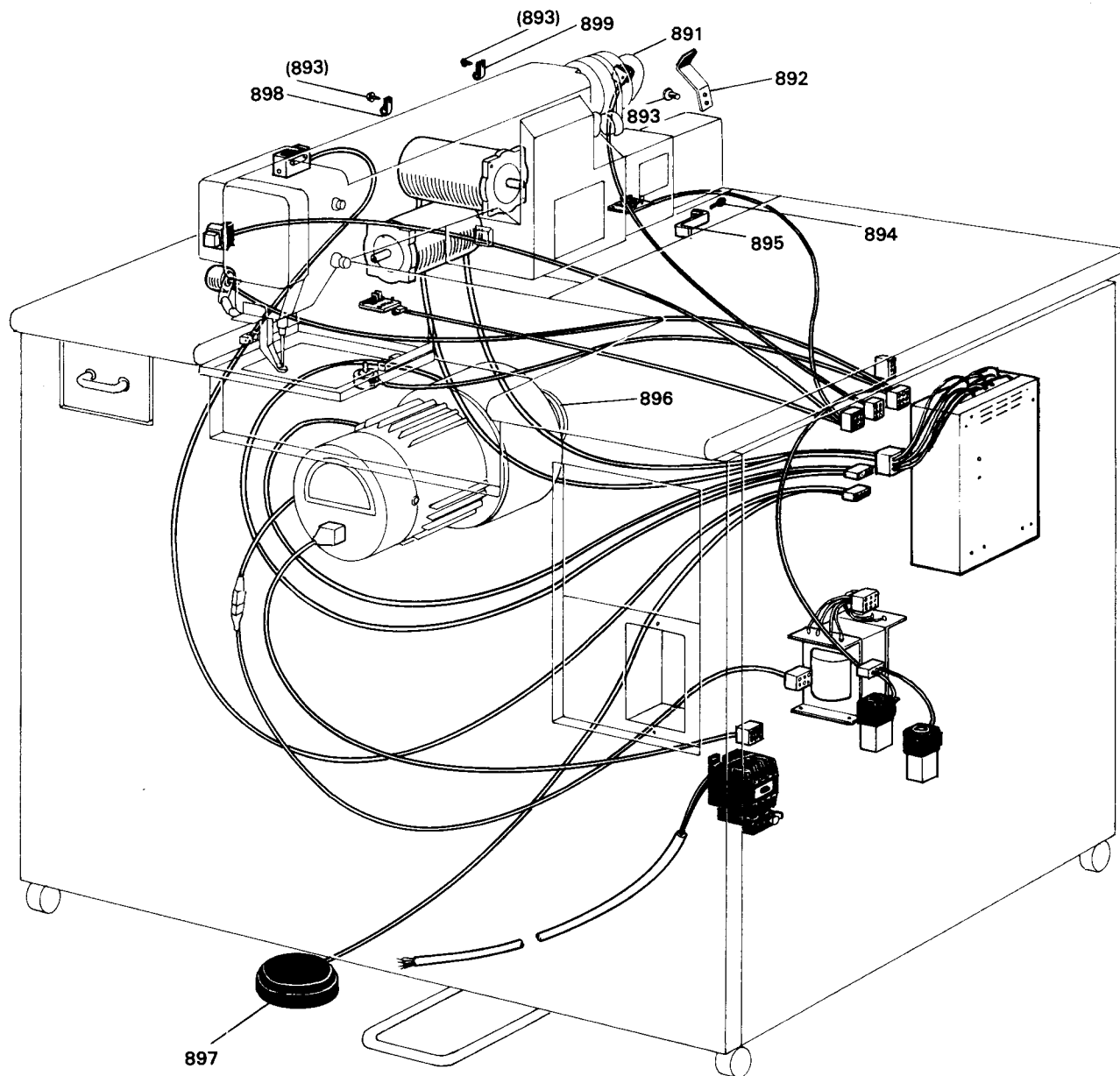

From the library of: Diamond Needle Corp

15 配線関係

WIRING CONNECTION MECHANISM

Fig. No.	部品コード Parts.No.	部品名	Parts name	使用 個数 Amt. Req.	資材コード Ref. No.
891	MS 02E1 406	検出器 (組)	Detector complete	1	A141D390G02
892	MS 02A0 802	回リ止メ	Stopper	1	A140D316G01
893	M9 0420 037	SW,PW,Pナベネジ M4×0.7×8	Screw M4×0.7×8	4	S902N034P08
894	M9 0418 037	SW PW,Pナベネジ M4×0.7×16	Screw M4×0.7×16	1	S902N034P16
895	MS 02A0 415	コード押エ	Cord holder	1	A140D351G01
896	MF 40A1 856	プーリ T-100	Pully	1	M997D115H01
897	M9 1000 090	フットスイッチ	Foot switch	1	A130C180G01
898	M9 4005 099	ナイロンクリップ HP-5N	Nylon clip	1	S945N220P05
899	M9 4007 099	ナイロンクリップ HP-6N	Nylon clip	1	S945N220P06

From the library of: Diamond Needle Corp

16 付 属 品
ACCESSORIES

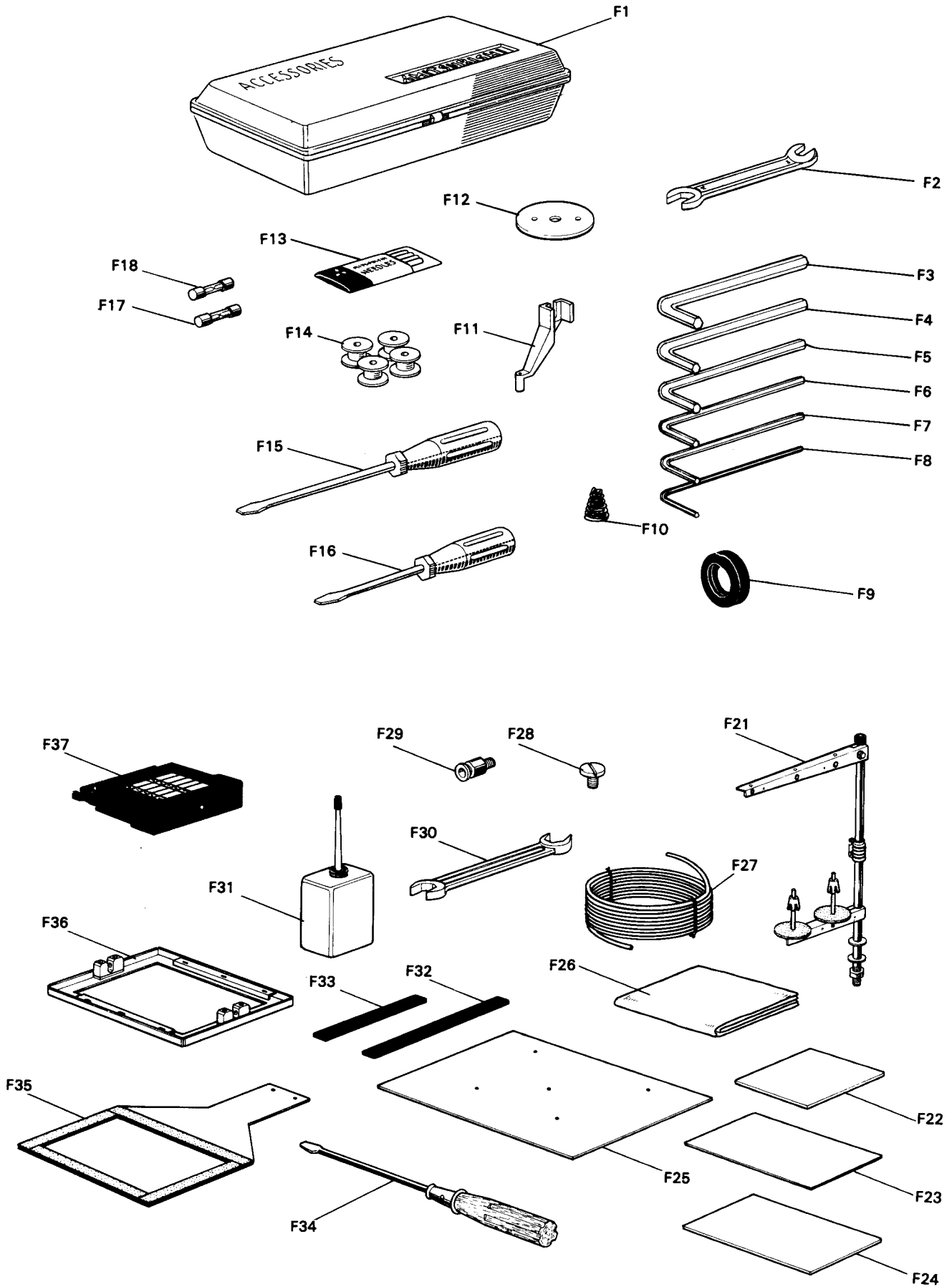

From the library of: Diamond Needle Corp

16 付 属 品 ACCESSORIES

Fig. No.	部 品 コー ド Parts. No.	部 品 名	Description	使用 個数 Amt. Req.	資 材 コー ド Ref. No.
F1	MF 60A0 749	付 属 品 箱	Accessory box	1	W231722H01
F2	MM 10A1 101	ス パ ナ 10×14	Spanner 10×14	1	B422776H01
F3	MS 05A0 976	六 角 棒 ス パ ナ 5	Socket wrench 5	1	S689N902P06
F4	MS 01A1 976	六 角 棒 ス パ ナ 4	Socket wrench 4	1	S689N902P05
F5	MF 90A0 976	六 角 棒 ス パ ナ 1/8	Socket wrench 1/8	1	W462660H01
F6	ML 35A2 976	六 角 棒 ス パ ナ 3	Socket wrench 3	1	S689N902P04
F7	ML 35A1 976	六 角 棒 ス パ ナ 2.5	Socket wrench 2.5	1	S689N902P03
F8	ML 35A0 976	六 角 棒 ス パ ナ 2	Socket wrench 2	1	S689N902P02
F9	MS 03A0 417	ゴ ム 輪	Rubber ring	1	A140D329H01
F10	MF 10A1 245	円 錐 バ ネ	Thread tension spring	1	W502193H01
F11	MV 30A1 256	中 押 エ	Presser foot φ2	1	A130C201H02
F12	MS 02A0 101	針 板 φ1.6	Needle plate φ1.6	1	A140D516H01
F13	MS 02A0 128	針 D P×17-18	Needle DP×17-18	10	S970005H05
F14	MG 44B0 123	ボ ビ ン	Bobbin	4	W470215H02
F15	MB 02A0 608	ド ラ イ バ (中)	Screw driver (middle)	1	P842003X01
F16	MB 02A1 608	ド ラ イ バ (小)	Screw driver (small)	1	P842002X01
F17	M9 1001 091	ヒ ュ ー ズ 125V 10A	Fuse 125V 10A	2	S460N011P36
F18	M9 1002 091	ヒ ュ ー ズ 125V 5A	Fuse 125V 5A	2	S460N011P35
F19					
F20					
F21	MS 05A0 193	糸 立 台 (組)	Cotton stand complete	1	A190D080P01
F22	MS 02A0 762	外 押 エ 板 (透明塩ビ) 2 t	Transparent plastic plate	2	A140D594H01
F23	MV 35A3 762	外 押 エ 板 (ベルポーレン) 1 t	Plastic plate	3	E702C397H04
F24	MV 35A1 762	外 押 エ 板 (ベルポーレン) 2 t	Plastic plate	3	E702C397H02
F25	MS 02A0 797	保 護 フ ィ ル ム	Protection sheet	1	A140D410H01
F26	MQ 10A0 734	ビ ニール カ バ ー	Polyethylene cover	1	W220627H04
F27	MS 02A2 567	チ ュ ー ブ	Tube	1	A141D171H01
F28	M9 5002 002	平 ネ ジ M10	Screw M10	4	A140D362H01
F29	MS 02A8 571	ワ ン タ ッ チ 継 手 1/4	Air fitting 1/4	1	A190N014P01
F30	MS 02A0 479	ス パ ナ 13×17	Spanner 13×17	1	A190N013P01
F31	MF 60A0 137	油 差 シ	Oiler with oil	1	P831001X01
F32	MS 02A1 416	ゴ ム 板 (長)	Clamp pad	2	A140D287H02
F33	MS 02A0 416	ゴ ム 板 (短)	Clamp pad	2	A140D287H01
F34	MF 60A0 608	ド ラ イ バ (大)	Screw driver (large)	1	W319408H01
F35	MS 02E0 272	下 押 エ (組)	Feed plate complete	1	A140D349G01
F36	MS 02E0 105	外 押 エ (組)	Clamp frame complete	1	A130C257G01
F37	MV 30E0 718	PROM付カセットケース(組)(1000針用)	Caset case with PROM (for 1000 stitches)	1	TE730D001G10

From the library of D. J. King

17 オプションパーツ OPTION PARTS

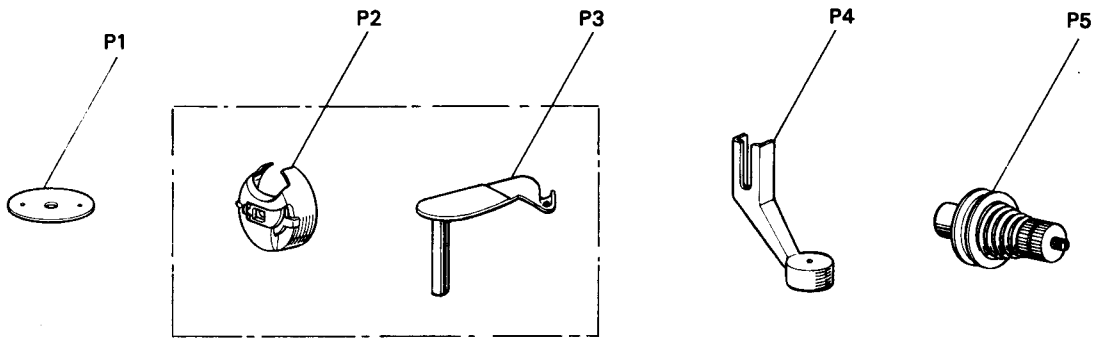

※ Fig P2とP3はセットで使用して下さい。
※ Please use the combination with P2 and P3.

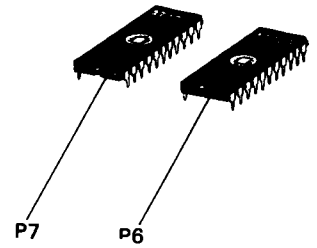
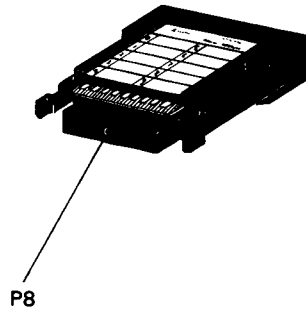
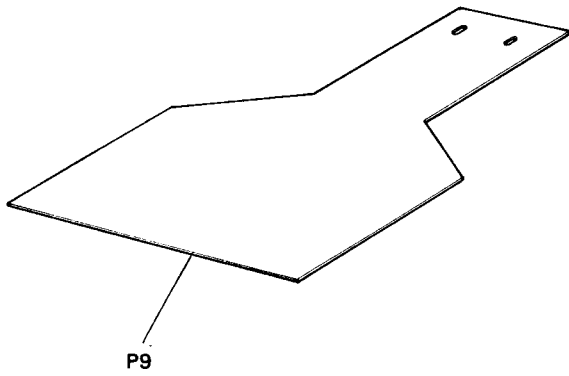

From the library of: Diamond Needle Corp

17 オプションパーツ OPTION PARTS

Fig. No.	部品コード Parts. No.	部 品 名	Parts name	使用 個数 Amt. Req.	資 材 コード Ref. No.
P1	MS 02A2 101	針 板 φ2.6 厚物用	Needle plate φ2.6		A140D516H03
P2	MS 05E0 125	ボビンケース 厚物用	Bobbin case		A190D073P01
P3	MG 44B0 838	移動メス (組)厚物用	Movable knife complete		A130C429G01
P4	MV 35A0 106	皿 押 エ φ3	Presser foot (φ12×φ3)		A130C274H01
P5	MF 82E0 210	上糸調節器 厚物用	Thread tension regulator complete		W346065G02
P6	MS 02A0 718	P R O M (2000針用)	PROM (for 2000 stitches)		2732A
P7	MV 30A0 718	P R O M (1000針用)	PROM (for 1000 stitches)		2716
	MS 02E1 718	PROM付カセットケース(組)(2000針用)	Cassctc case with PROM (for 2000 stitches)		TE730D001G30
P8	MS 02E0 718	PROM付カセットケース(組)(4000針用)	Cassete case with PROM (for 4000 stitches)		TE730D001G40
	MS 02E2 718	PROM付カセットケース(組)(PROMナシ)	Cassete case (without PROM)		TE730D001G50
P9	MS 02A2 272	送 り 板	Feed plate		A140D870H02

From the library of: Diamond Needle Corp